



BYD Battery-Box LV Installation Guidance

Battery-Box L 3.5/7.0/10.5/14.0 (AU)

Version1

Contents

1 Safety	5
1.1 Danger.....	5
1.2 Warming	5
1.3 Caution.....	5
1.4 Environmental and transport requirement	6
1.5 Notice	7
2 Information	7
2.1 Product profile.....	7
2.2 Appearance dimension	7
2.2.1 BCU Introduction	8
2.2.2 Description of B-Plus L 3.5 Interface and Terminal	9
2.3 Delivery contents	9
3 Installation	9
3.1 Tools & safety gears required	10
3.1.1 Tools	10
3.1.2 Safety gears for personal protection	10
3.2 Unboxing the package.....	10
3.2.1 Items in the package.....	11
3.3 Level.....	11
3.3.1 Separate BCU and base	11
3.3.2 Adjust the level of the base.....	11

3.4 Battery Module Installation.....	12
3.5 Mounting bracket	12
3.6 Open the BCU Cover.....	14
3.7 Power Cables, Ground Cable, Communication Cable & WIFI Cable Connection.	15
3.8 Install WIFI Module	15
3.9 Installation Complete for Single System.....	16
3.10 Installation Complete for Parallel System Connection	16
4 Checking list of the Battery-Box.....	18
5 Run and shut down the Battery-Box system	19
5.1 Turn on the Battery-Box system.....	19
5.2 Turn off the Battery –Box system	19
6 Software Program Update and WIFI Network Configuration	20
6.1 Down Load the Firmware	20
6.2 Connect to WIFI	20
6.3 Software Program Update via WIFI.....	20
6.4 BYD Remote Update.	22
6.5 View Batter-Box system information.....	22
6.6 Configure the Network of WIFI	23
7 WIFI and system status indicator	24
System status indicator	24
8 Common Issues and Solutions.....	24

8.1 Common Issues of BYD Battery-Box LV and Solutions	24
8.2 Emergency.....	24
9 Contact	25
Appendix	25
1 CAN interface definition of BCU & inverter	25
1.1 Connection with SMA	26
1.2 Connection with GOODWE.....	26
1.3 Connection with VICTRON	27
1.4 Connection with SUNGROW	27
1.5 Connection with SOLIS	28
2 Parameter settings of Inverter	28
2.1 SMA Min Capacity.....	28
2.2 GOODWE Min Capacity.....	29
2.3 VICTRON Min Capacity.....	29
2.4 SUNGROW Min Capacity	29
2.5 Solis Min Capacity.....	30
3 Troubleshooting and maintenance	30
3.1 Battery-Box troubleshooting and maintenance	30
3.2 Inverter troubleshooting and maintenance.....	30
3.2.1 Alarm Code Displayed On the SRC of SMA Sunny Island and Solution	
30	
3.2.2 Alarm Displayed On the APP of GOODWE and the Solution.....	32

1 Safety

This section contains safety information that must be observed at all times when working on or with batteries. To prevent personal injury or property damage and to ensure long-term operation of the batteries, read this section carefully and observe all safety information at all times.

1.1 Danger

Please cut off the power supply and turn off the battery in emergency. For example, when there is an emergency such as smoke, fire, burning, explosion, etc.

1.2 Warning

- a) When increase battery, power off the battery and other power input first.
- b) Disconnect battery from power and load, then power off battery before installation and maintenance.
- c) Continuous operation on a damaged battery can result in dangerous situation that may cause severe injury due to electrical shock.
- d) Do not use the damaged or deformed batteries
- e) By checking to verify the installation settings are correct.
- f) In case any issue arises during commissioning, the system must be shut down immediately and reported to the after sales service
- g) Please do not stack up batteries without protective package when storing or handling batteries, unless in the case of installation.

1.3 Caution

- a) Do not disassemble the battery.
- b) Do not touch the battery pack with wet hands.
- c) Do not crush, drop or puncture the battery.
- d) Always dispose according to local safety regulations.
- e) Store and recharge battery according to user manual strictly.
- f) Ensure reliable grounding.
- g) Do not reverse polarity
- h) Do not short circuit the terminals, remove all jewelry items that could product a short circuit.
- i) Do not stack up batteries without package.
- j) The packed batteries are not allowed to be stacked up more than specified layers stipulated on the package.
- k) After installation, if the system cannot work properly, please contact the after-sales service

partner. If it still cannot be solved, make sure to turn off the Battery-Box before you leave the site.

1.4 Environmental and transport requirement

- a) Do not expose the battery to temperature above 50°C.
- b) Do not place the battery near any heat sources and avoid sparks.
- c) Do not expose the battery to moisture or liquids.
- d) Stay away from corrosive gases and liquids, as well as radiation.
- e) Do not expose the battery to direct sunlight.
- f) Place battery in secure location away from children and animals.
- g) Do not allow the battery power terminals to touch conductive objects such as wires.
- h) The installation should be clean, flat, dry. Not be installed in damp situations, including:
 - ☛ Baths, showers and other fixed water containers
 - ☛ Swimming pools, paddling pools and spa pools or tubs
 - ☛ Fountains and water features
 - ☛ Saunas
 - ☛ Refrigeration rooms
 - ☛ Sanitization and general hosing-down operations
- i) The Battery-Box LV system can be installed at altitudes of up to 2000m above Mean Sea Level.
- j) The product installation location should be reserved for 0.9m safe passage distance.
- k) Due to the heavy weight of Battery-Box L 3.5-14.0, please use strong packaging and safety protection equipment during transportation, to ensure safety and avoid accidental damage. Please handle with care.
- l) In the process of transportation and storage, the goods are not allowed to be stacked in layers or at a height greater than specified.

Environmental requirements

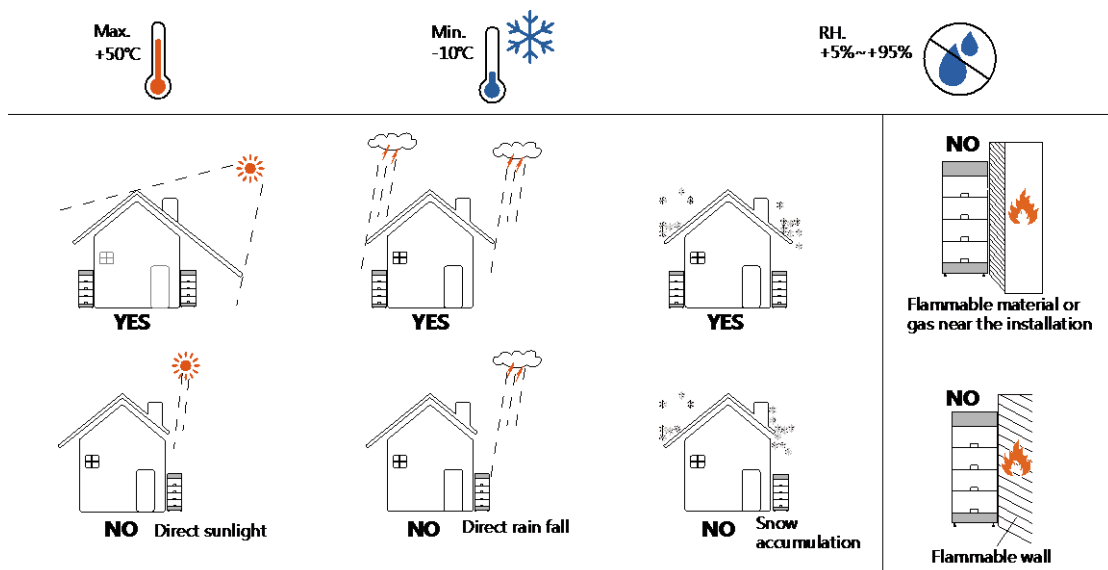

1.5 Notice

Skilled personnel recognized

This manual and the tasks and procedures described herein are intended use by skilled workers only. A skilled worker is defined as a trained and qualified electrician or installer who has all of the following skills and experience:

- a) Knowledge of the function principles and operation of on-grid systems.
- b) Knowledge of the dangers and risks associated with installing and using electrical devices and acceptable mitigation methods.
- c) Knowledge of the installation of electrical devices
- d) Knowledge of and adherence to this manual and all safety precautions and best practices.

2. Information

2.1 Product profile

This user manual introduces the BYD Battery-Box LV product information, using guidance, safety, common issues and actions.

The BYD Battery-Box L 3.5/7.0/10.5/14.0 is an energy storage unit that can be used in On-grid system for commercial & residential application.

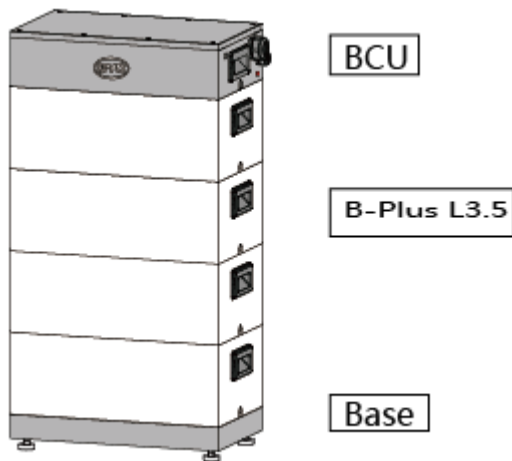

2.2 Appearance dimension

2.2.1 BCU Introduction

The battery management and control part, which contains BCU and charge-discharge relay, and connected to the battery modules underneath and to inverter or BMU above.

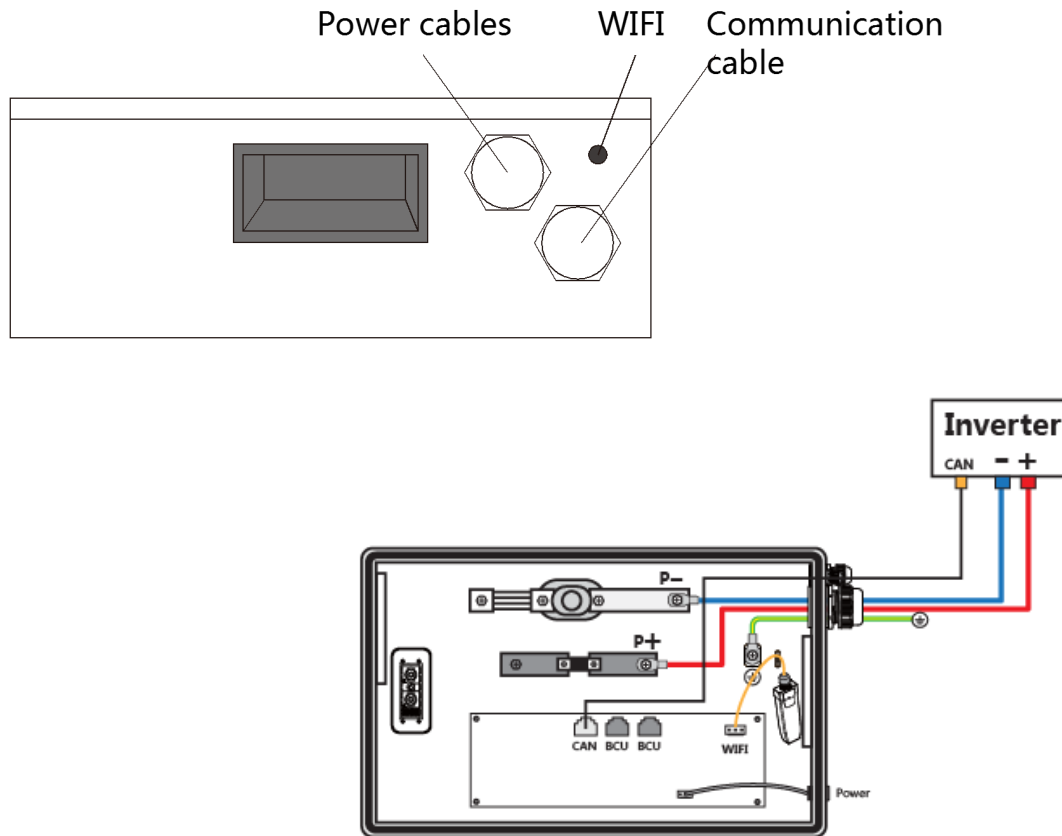

2.2.2 Description of B-Plus L 3.5 Interface and Terminal

The battery module provides energy and sends the information about the cell voltage and cell temperature in the battery module to the upper-layer BCU.

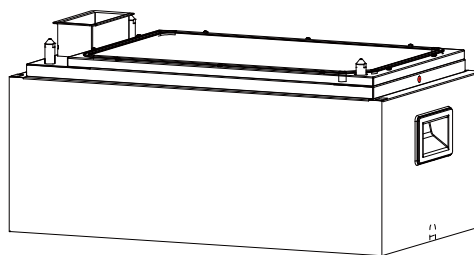

2.3 Delivery contents

Type	3.5KWh	7.0 KWh	10.5 KWh	14.0KWh
BCU + Base	1	1	1	1
B-Plus L3.5A	1	2	3	4

3. Installation

- a) Wear appropriate safety gear before installation.
- b) The connecting cables for installing batteries shall be as short as possible, to prevent excessive voltage drop.
- c) Batteries of different capacity, different P/N or from different manufacturers cannot be connected.
- d) After installation, make sure power cables and communication cables, grounding cables, etc. are properly connected according to the installation manual.
- e) The installation place shall be on a flat ground, without accumulated water, and should keep the battery system away from heat source.
- f) An external Bi-Polar DC isolator between battery and inverter is required during installation.
- g) The battery system shall be mounted with the highest point no greater than 2.2 m above the floor level.
- h) The aisle width shall be not less than 600 mm.
- i) A minimum of 25 mm clearance between battery modules and any wall or structure on a side not requiring access for maintenance.
- j) The battery system shall not be installed within 600mm any hot water unit or air conditioning unit or any other appliance not associated with the battery system.
- k) The battery system shall be installed in accordance with the relevant local regulations or standards.

3.1 Tools & safety gears required

3.1.1 Tools

The following tools are required to install the battery pack and BCU.

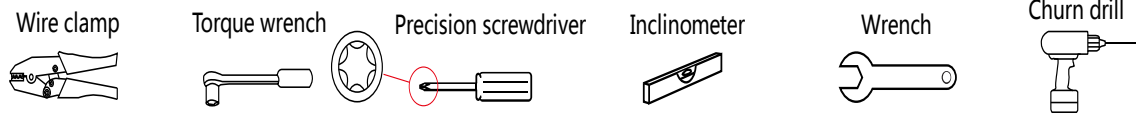

3.1.2 Safety gears for personal protection

It is recommended to wear the following safety gears when handling the battery pack.



Insulated gloves



Safety shoes

3.2 Unboxing the package

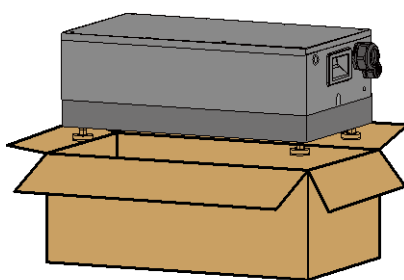

BCU

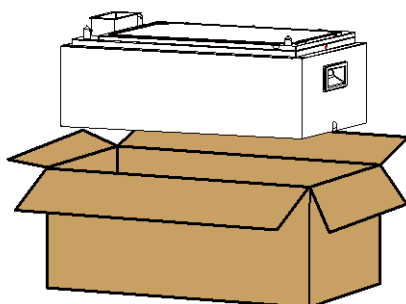
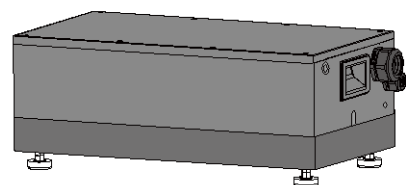

B-PLUS

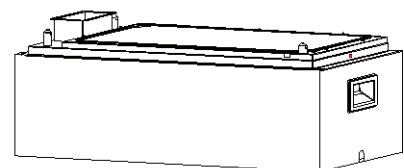

3.2.1 Items in the package

BCU & BASE	
Name	Quantities
M6 precision screwdriver	4
M8 Phillips screwdriver	1
M10 hexagonal screw	1
M6 expansion	3
Black Sealing plug	2
WIFI module	1
Quick reference guide	1
Notice	1
User manual	1
RED Declaration of Conformity	1

B-plus L 3.5	
M6 precision screwdriver	2
MSDS	1
Black Sealing plug	2

3.3 Level

3.3.1 Separate BCU and base

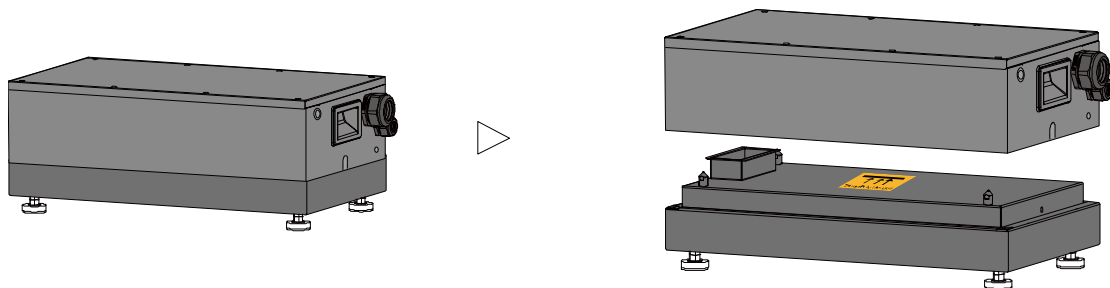

3.3.2 Adjust the level of the base

The base is placed against the wall, and the distance between the base and the wall is 0-50mm.

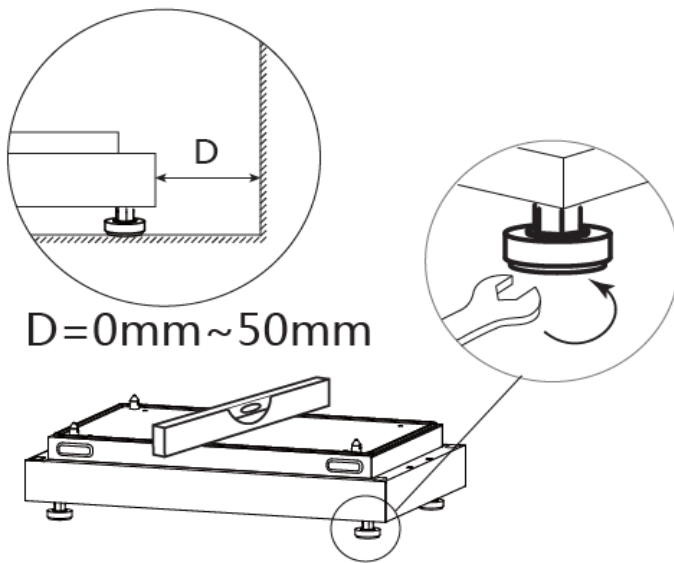

3.4 Battery Module Installation

When installing the battery module, make sure the previous battery module is installed and locked before installing the next battery module. Please install the battery modules one by one.

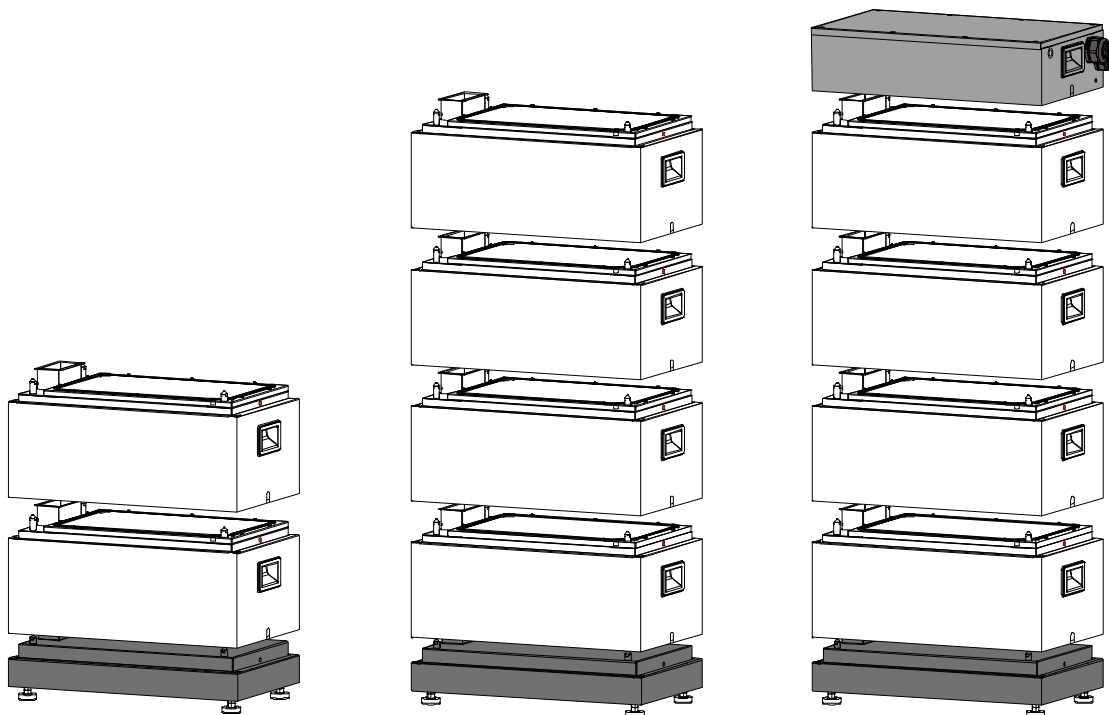

3.5 Mounting bracket

- a) Use a pencil to mark the location of the hole to be drilled.
- b) Remove the BCU, punch holes in the wall with hammer drill.

- c) Install expansion bolt in punched holes.
- d) Install the BCU, then lock the crews and expansion bolt.

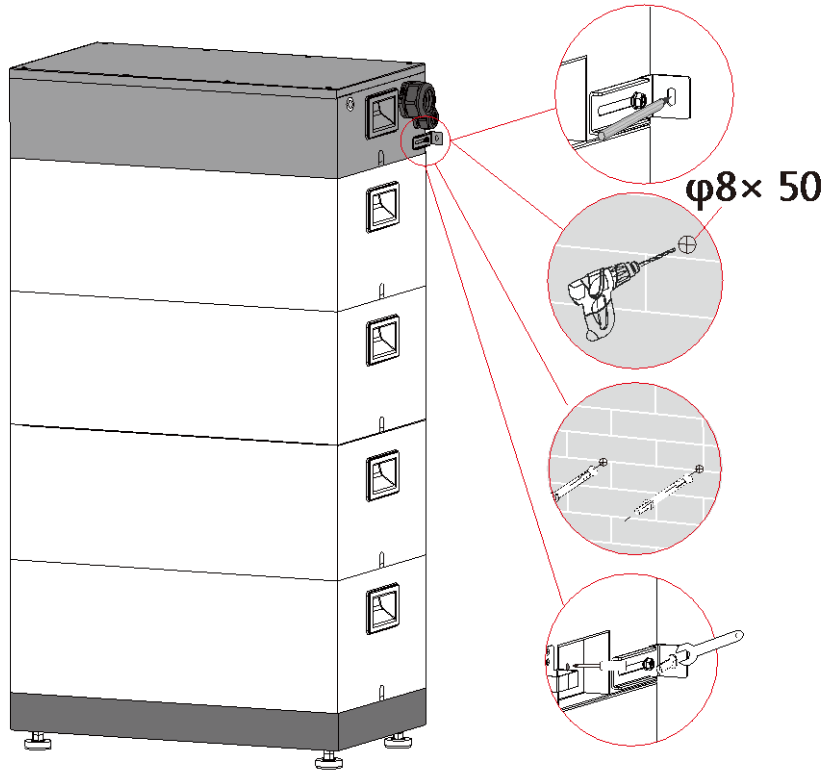

3.6 Open the BCU Cover

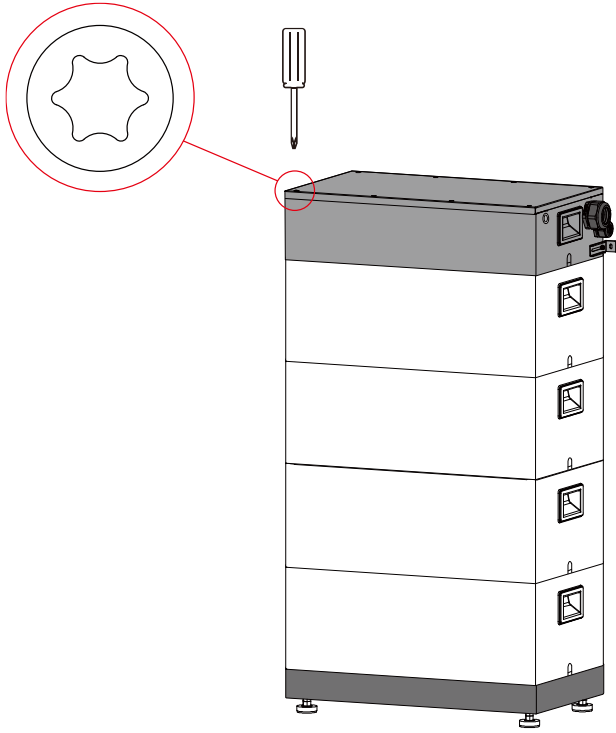

3.7 Power Cables, Ground Cable, Communication Cable & WIFI Cable

Connection.

Torque value: M8*16mm : 10±0.2 N.m; M10×20mm: 22.5±2.5N.

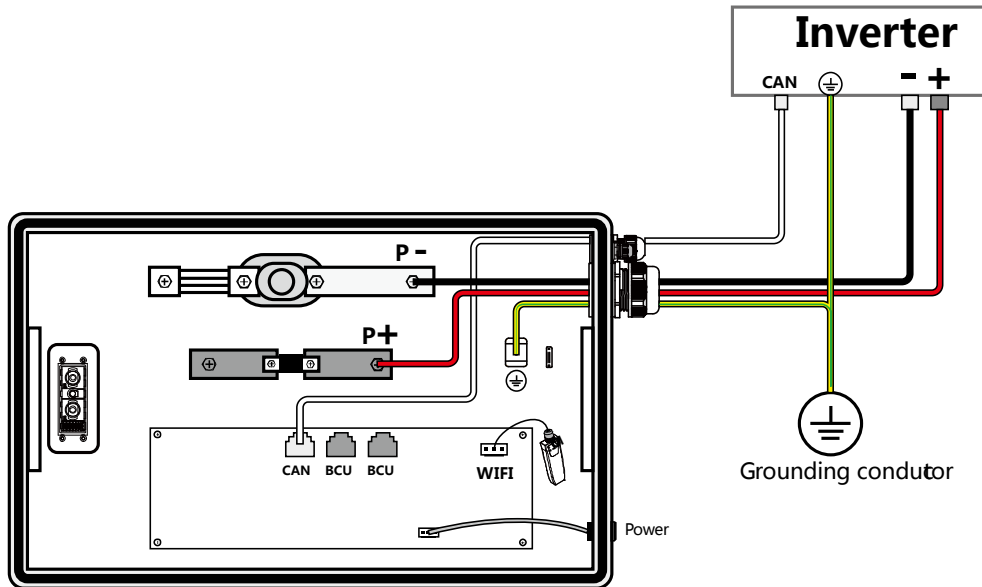

RJ45 Pin define

	Battery-Box	SMA	GOODWE	VICTRON	SUNGROW	Solis
CAN H	4	4	4	7	CAN H	4
CAN L	5	5	5	8	CAN L	5

CAN is connected to the inverter. BCU1 and BCU2 are for parallel connection.

3.8 Install WIFI Module

- 1.Connect the wifi cable to the wifi module.
- 2.Install the wifi module.

If 2 or 3 systems are connected in parallel, only the master (communicating with the inverter) is connected to the wifi module. Please disconnect or remove the other wifi module.

Turn the knob counterclockwise when connect the wifi cable to the wifi module.

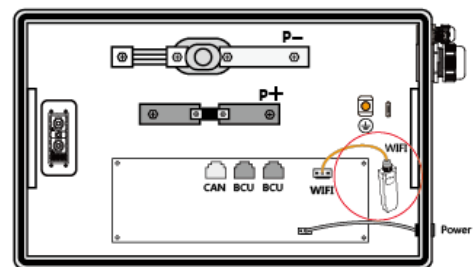
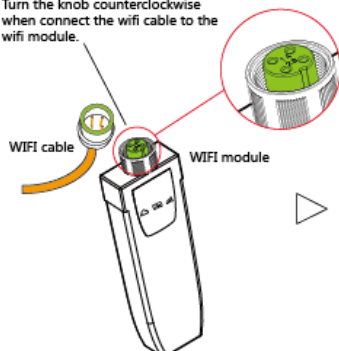

3.9 Installation Complete for Single System

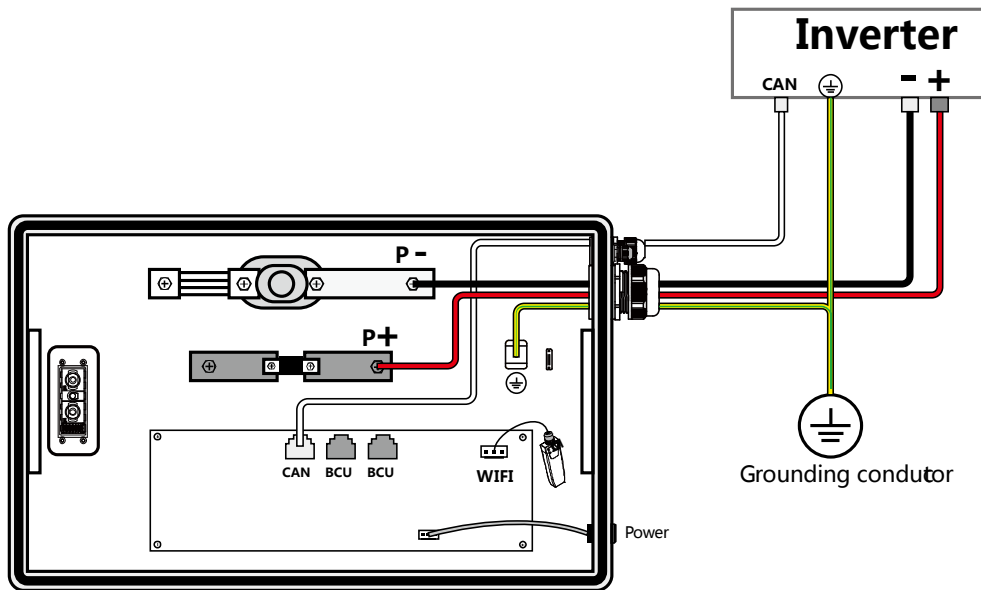

3.10 Installation Complete for Parallel System Connection

If connecting 3 BCU in parallel, unplug the jumper on the second BCU PCBA.

If connecting 2 BCU in parallel, you don't need to unplug the jumper.

If the system is installed in parallel, it is only necessary to install the WIFI module as a host in one of the systems, and the remaining systems do not need to install the WIFI module as the slave.

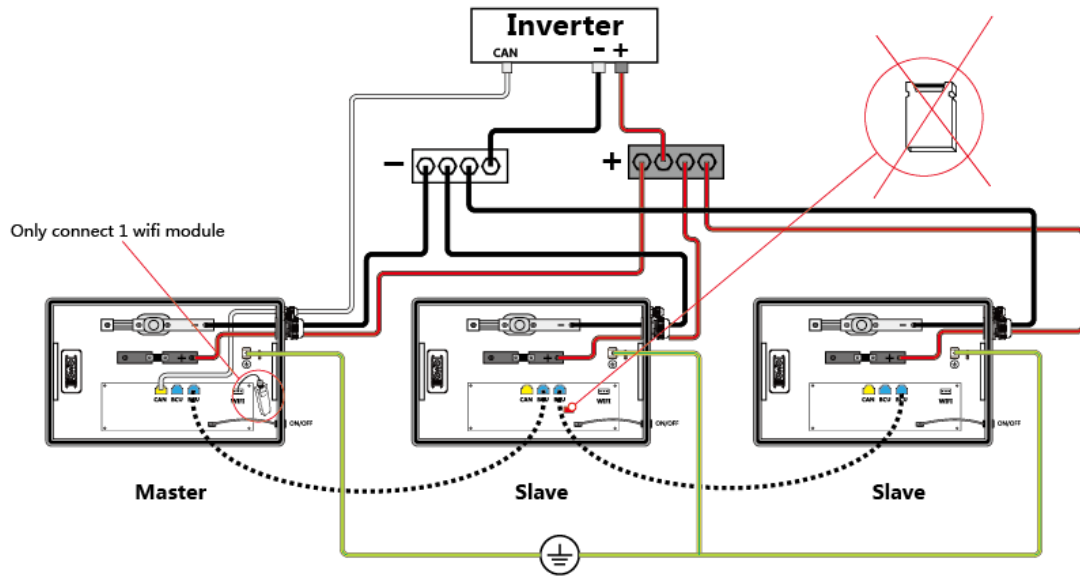

4 Checking list of the Battery-Box

The purpose is to check the connection and parameters setting between the Battery-Box L 3.5-14.0 and the inverter.

The above inspection is only related to Battery-Box. For other inspection, please refer to the inverter user manual and installation manual.

After the Battery-Box is installed, check the cable connections according to the following table for correct and reliable. If not, follow the instructions in the installation manual and the quick installation manual.

Task	Check
1.Screws(Battery Module; BCU, Positive/Negative and Ground cable)	<input type="checkbox"/> Yes <input type="checkbox"/> No
2.Water proof joint	<input type="checkbox"/> Yes <input type="checkbox"/> No
3.Hangers	<input type="checkbox"/> Yes <input type="checkbox"/> No
4.Positive cable	<input type="checkbox"/> Yes <input type="checkbox"/> No
5.Negative cable	<input type="checkbox"/> Yes <input type="checkbox"/> No
6.Ground cable	<input type="checkbox"/> Yes <input type="checkbox"/> No
7.Communication(CAN) cable	<input type="checkbox"/> Yes <input type="checkbox"/> No
8 BCU cable(check this in parallel)	<input type="checkbox"/> Yes <input type="checkbox"/> No
9 WIFI cable	<input type="checkbox"/> Yes <input type="checkbox"/> No
10 Jumper(*Check this in parallel with three sets)	<input type="checkbox"/> Yes <input type="checkbox"/> No
11 WIFI Setting	<input type="checkbox"/> Yes <input type="checkbox"/> No
12.Battery-Box parameters setting on inverter	<input type="checkbox"/> Yes <input type="checkbox"/> No
13. BCU software update (if required)	<input type="checkbox"/> Yes <input type="checkbox"/> No

5 Run and shut down the Battery-Box system

5.1 Turn on the Battery-Box system

Press the switch with your finger for about one second.



5.2 Turn off the Battery –Box system

Press the switch with your finger for about 3 to 5 seconds.



6 Software Program Update and WIFI Network Configuration

6.1 Down Load the Firmware

- a) www.eft-systems.de (Support->Downloads)
- b) <http://alpspower.com.au/download>

6.2 Connect to WIFI

You can use a computer, mobile phone or IPAD to set up and configure;

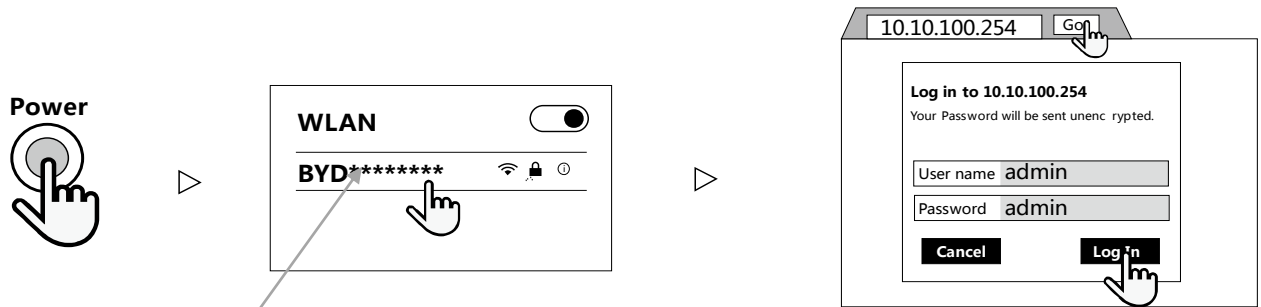

This number is the same as the S/N on the WIFI nameplate .No password is needed here.

6.3 Software Program Update via WIFI

When updating the software program via WIFI, the sign of the success of the update is to hear the buzzer sound twice from the Battery-Box system and web page reminder update is successful. It takes about 1 minutes to complete the update.

"Upgrade>WIFI "It is for Update WIFI software program, you don't have to do it.

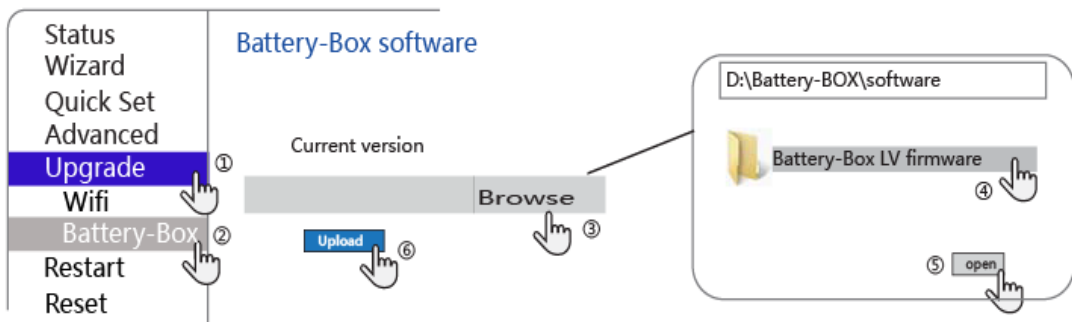

There will be a progress bar during the update process, as shown in the following figure.

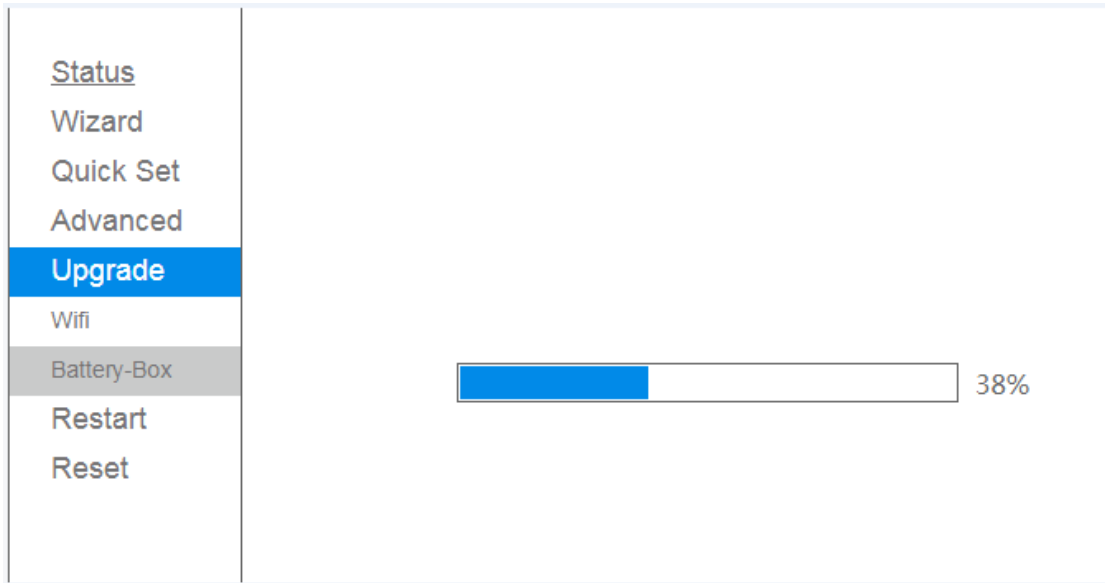

The interface for the successful update of the software program is shown below.

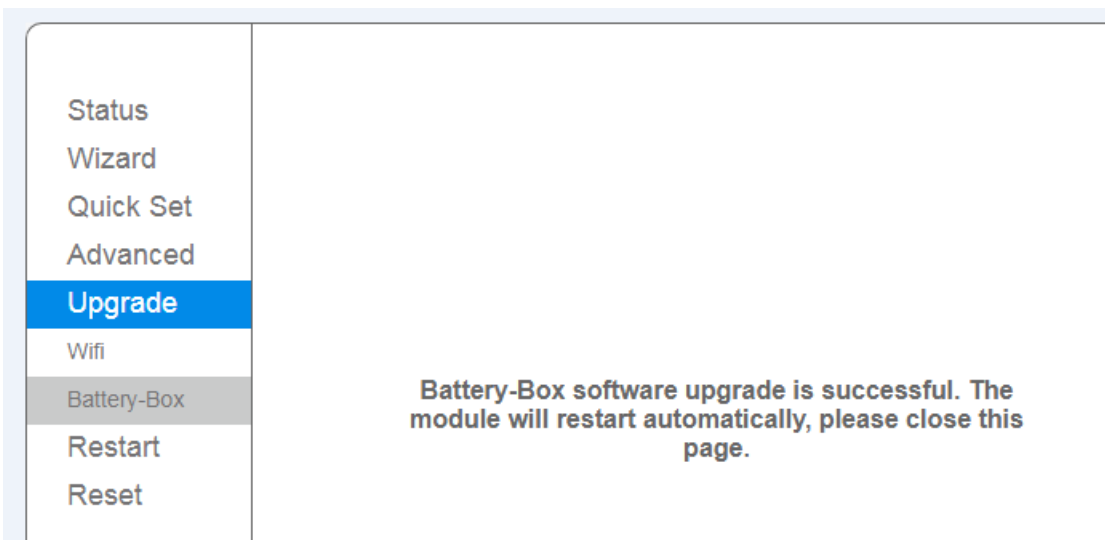

If the program update fails, you will get the following prompt.

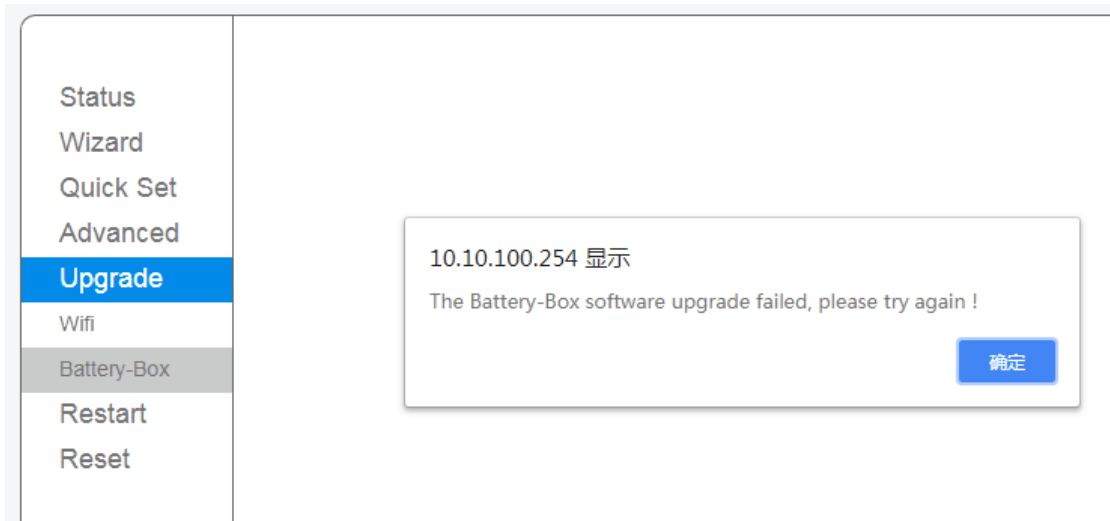

6.4 BYD Remote Update.

This is done in compliance with the law and with the consent of the customer.

This requires a successful configuration of the WIFI network, and the Battery-Box system must be online.

6.5 View Batter-Box system information

Checking the battery status by typing the URL.

BCU1	
BCUStatus	-
BICNum	0
BIC1Status	-
BIC2Status	-
BIC3Status	-
BIC4Status	-
BIC5Status	-
VerY-M-D	0/0/0
Ver	V0-0

BCU2	
BCUStatus	-
BICNum	0
BIC1Status	-
BIC2Status	-
BIC3Status	-
BIC4Status	-
BIC5Status	-
VerY-M-D	0/0/0
Ver	V0-0

BCU3	
BCUStatus	-
BICNum	0
BIC1Status	-
BIC2Status	-
BIC3Status	-
BIC4Status	-
BIC5Status	-
VerY-M-D	0/0/0
Ver	V0-0

6.6 Configure the Network of WIFI

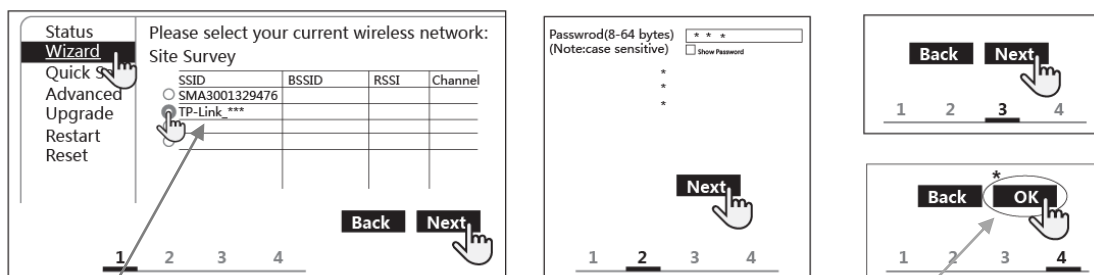

Please select your current wireless network:

*After clicking "OK", you need to wait for 15 seconds to close the webpage. Otherwise, the configuration is unsuccessful. Need to reconfigure.

After the WIFI network is configured, if you want to reconfigure the network, the best way is to restart the Battery-Box system. Then follow the steps to configure the WIFI network.

7 WIFI and system status indicator

System status indicator

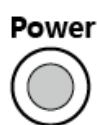

	Diagram	Status	Meaning
1		White blink slow	Charging
2		White blink fast	Discharging
3		White always ON	Idle
4		White blink very slow	Idle
5		Orange blink 2 times	System WIFI is lost
6		Orange blink 3 times	Loss of inverter communication
7		Orange blink 4 times	Lost slave CAN communication
8		Orange blink 5 times	Uncalibrated
9		Orange always ON	BCU or Battery failure

8 Common Issues and Solutions

8.1 Common Issues of BYD Battery-Box LV and Solutions

Issue Description	Possible causes	Solution
Contactor disconnected	<ol style="list-style-type: none"> 1. Battery voltage is too low 2. Battery voltage is too high 3. Battery temperature is too high 4. Battery current is too high 5. Other hardware failures. 	Please contact our after-service provider immediately.

User also can monitor the running status of battery, warning and alarm information from App or LED display of inverter.

8.2 Emergency

Please cut off the power supply and turn off the battery in emergency. Contact our after-service provider immediately

9. Contact

If you have technical problems with our products, please contact the customer service. The following data is required in order to provide you with the necessary assistance:

- Battery system:
 - Type
 - Serial number of BCU and each Batteries
 - Quantities of battery
 - Event message and Error discription
 - Mounting location
 - Installation date and Installation environment(out door or indoor)
- Battery inverter:
 - Device type
 - Serial number
 - Firmware version
 - Event message
 - Optional equipment, e.g. communication products
 - Use the name of the system of the system in inverter remote monitoring (if available)
 - Access data for Inverter remote monitoring (if available)
 - Special country-specific settings (if available)

Appendix

In addition to the cable connections and parameter settings given in this manual, please refer to the inverter's user manual and installation manual for other cable connections and parameter settings.

1. CAN interface definition of BCU & inverter

RJ45 PIN define

	Battery-Box	SMA	GOODWE	VICTRON	SUNGROW	Solis
CAN H	4	4	4	7	CAN H	4
CAN L	5	5	5	8	CAN L	5

1.1 Connection with SMA

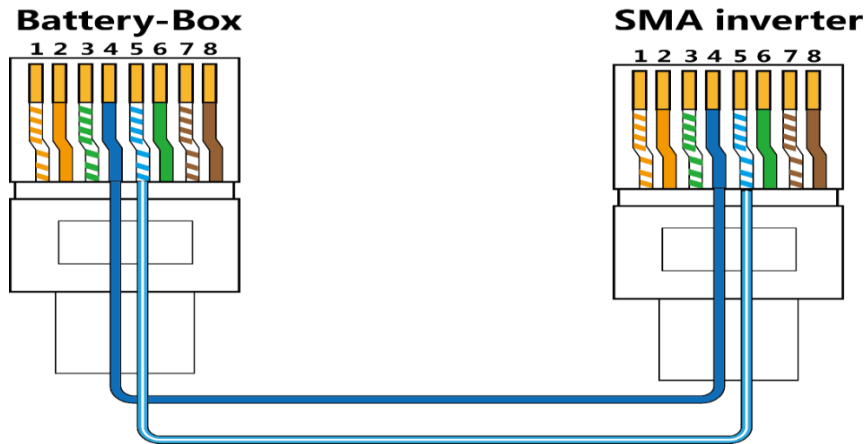

1.2 Connection with GOODWE

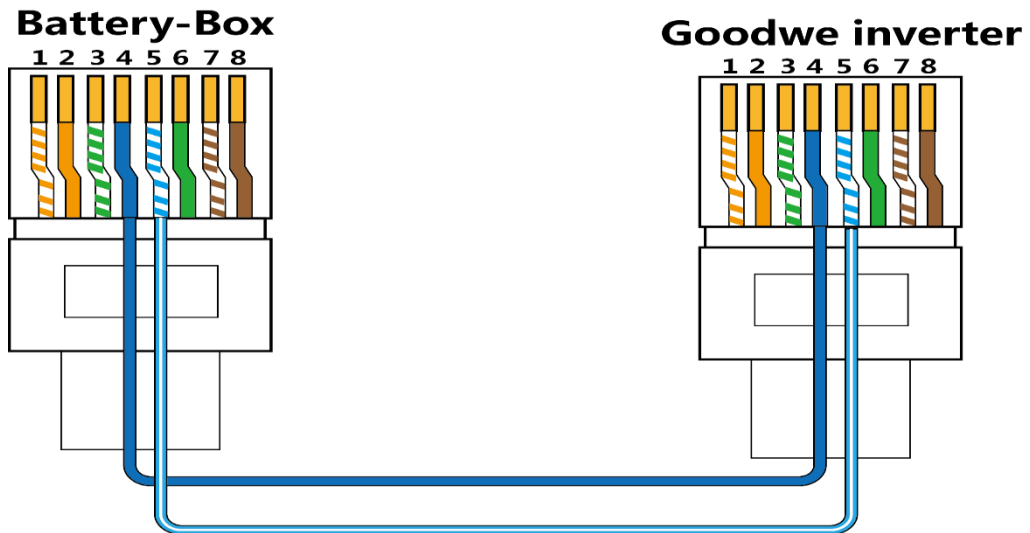

1.3 Connection with VICTRON

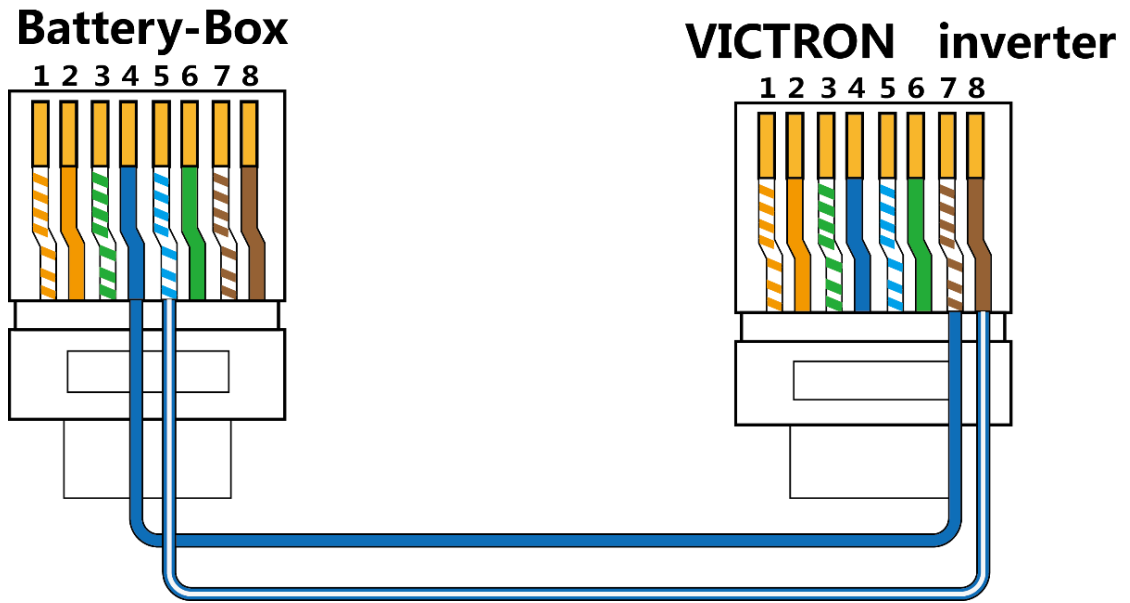

1.4 Connection with SUNGROW

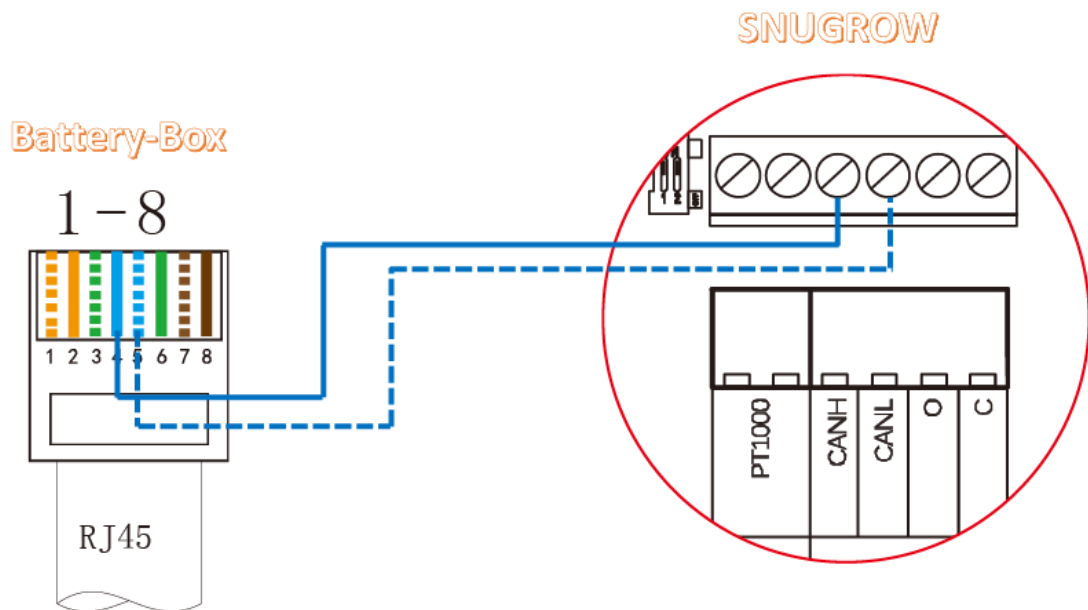

1.5 Connection with SOLIS

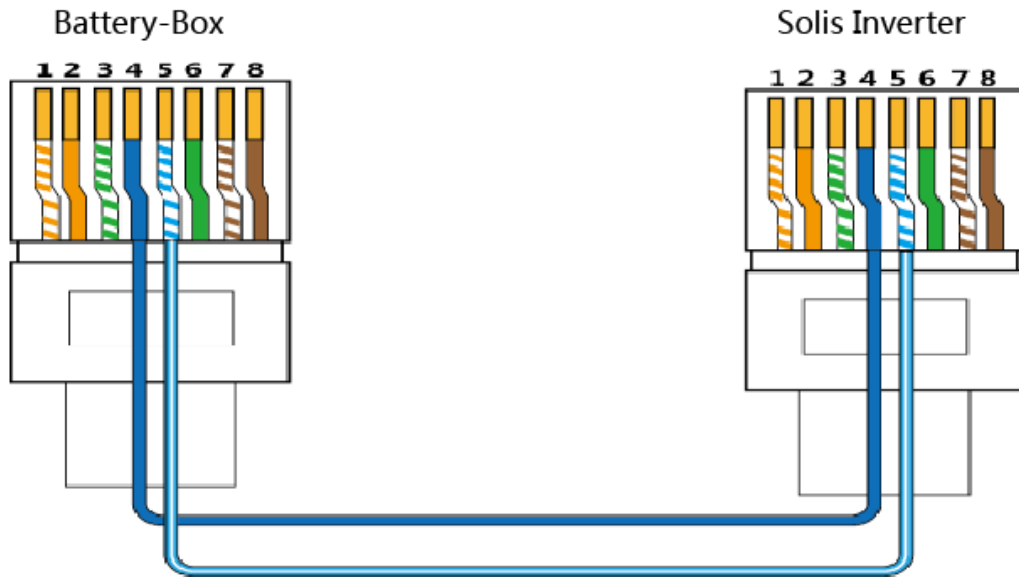

2. Parameter settings of Inverter

2.1 SMA Min Capacity

Charging the battery usage through system for increased self-consumption without a battery backup grid				
	Battery-BOX L 3.5	Battery-BOX L 7.0	Battery-BOX L 10.5	Battery-BOX L 14.0
Edit Parameters > Battery > Areas of application	Setup value	Setup value	Setup value	Setup value
Battery Type	Lithium-Ion(Li-Ion)	Lithium-Ion(Li-Ion)	Lithium-Ion(Li-Ion)	Lithium-Ion(Li-Ion)
nominal capacity	70	140	210	280
Season operation active	Yes	Yes	Yes	Yes
Low lmt deep disch. protect area prior shut down	3	3	3	3
minimum width of deep discharge protection area	2	2	2	2
minimum width of backup power area	0	0	0	0

area width for conserving battery state of charge	10	5	5	5
Charging the battery usage through battery backup system with increased self-consumption				
	Battery-BOX L 3.5	Battery-BOX L 7.0	Battery-BOX L 10.5	Battery-BOX L 14.0
Edit Parameters >Battery>Areas of application	Setup value	Setup value	Setup value	Setup value
Battery Type	Lithium-Ion(Li-Ion)	Lithium-Ion(Li-Ion)	Lithium-Ion(Li-Ion)	Lithium-Ion(Li-Ion)
nominal capacity	70	140	210	280
Season operation active	Yes	Yes	Yes	Yes
Low lmt deep disch. protect area prior shut down	3	3	3	3
minimum width of deep discharge protection area	2	2	2	2
minimum width of backup power area	5	10	10	10
area width for conserving battery state of charge	10	5	5	5

2.2 GOODWE Min Capacity

Battery type selection and discharge of depth parameters are set by GOODWE inverter APP.

Select the battery module: Battery-Box L 3.5 or Battery-Box L 7.0+.

	Battery-Box L 3.5	Battery-Box L 7.0	Battery-Box L 10.5	Battery-Box L 14.0
Depth of discharge	85%	90%	90%	90%

2.3 VICTRON Min Capacity

Parameters	Battery-Box L 3.5	Battery-Box L 7.0	Battery-Box L 10.5	Battery-Box L 14.0
Minimum discharge SOC	15%	10%	10%	10%

2.4 SUNGROW Min Capacity

Battery type selection and depth of discharge parameters are set via the SUNGROW inverter operator panel.

Select the battery module: Li-ion BYD.

Tot Cap (KWh): Write the actual capacity of the battery module here.

When the system is Battery-Box L 3.5, you need to turn on the forced charging function, and then set the corresponding parameters.

Forced Charge	Start time	End Time	Target SOC
Enable	00:00	23:59	15%

2.5 Solis Min Capacity

Battery type selection and depth of discharge parameters are set via the Solis inverter operator panel.

Select the battery module: B-BOX LV.

	Battery-Box L 3.5	Battery-Box L 7.0	Battery-Box L 10.5	Battery-Box L 14.0
Overdischg SOC	15%	10%	10%	10%

3. Troubleshooting and maintenance

3.1 Battery-Box troubleshooting and maintenance

The battery operation data, alarm information, historical alarm information and historical data of the Battery-Box system can be viewed through the software of the upper computer.

Issue Description	Possible causes	Solution
Contactor disconnected	Battery voltage is too low	Please contact our after-service provider immediately.
	Battery voltage is too high	
	Battery temperature is too high	
	Battery current is too high	
	Other hardware failures.	

3.2 Inverter troubleshooting and maintenance

3.2.1 Alarm Code Displayed On the SRC of SMA Sunny Island and Solution

SMA SRC	Possible causes	Solution
F221	External Alarm-Invalid Bat Type	Reset battery type to "Li" on SRC.
F920(XA01General)	1.AnyB-Plus L3.5 has failed to communicate with the BCU;	1. Check if the modules are connected correctly and all screws are fixed tightly.

		2.Replace BCU ;
F921(XA02DcHiVolt)	External Alarm - Battery High Voltage	If the red led of the BCU is on, please contact the service provider to change the battery. If not, check the system setting according to the guidelines.
F922(XA03DcLoVolt)	External Alarm - Battery Low Voltage	
F923(XA04DcHiTmp)	External Alarm - Battery High Temp	
F924(XA05DcLoTmp)	External Alarm - Battery Low Temp	
F925(XA06DcHiTmpC)	External Alarm - Battery High Temp Charge	
F926(XA07DcLoTmpC)	External Alarm - Battery Low Temp Charge	
F927(XA08DcHiCur)	External Alarm - Battery High Current Discharge	
F928(XA09DcHiChgCur)	External Alarm - Battery High Current Charge	
F930(XA11Short)	External Alarm - Short circuit	1.Power off; 2.Check if there is short connection of cable between P+&P-; 3.If short connection is confirmed, please reconnect cable correctly; 4.restart battery;
F931(XA12Bms)	External Alarm - BCU internal	If the red led of the BCU is lit, please contact the service provider to change the battery. If not, check the system settings according to the guidelines.
F932(XA13CellBal)	External Alarm - Cell imbalance	
F952	External Alarm -Ext BCU Timeout	1.Check whether the CAN communication cables are connected correctly and tightly ; 2.Replace BCU ;

3.2.2 Alarm Displayed On the APP of GOODWE and the Solution

APP of GOODWE	Possible causes	Solution
BMS status: Battery communication fail	Inverter and BCU communication failure	1.check whether the CAN communication cable has been connected correctly and tightly ; 2.Change BCU ;

Headquarter

China

BYD LITHIUM BATTERY Co., LTD

E-Mail: eubatterygrp@byd.com

Tel: +86 0755 89888888

Fax: 0755-8961 9653

Address: No.1 Baoping Road, Baolong Industrial Town, Longgang Shenzhen, 518116, China

Local Contacts

Australia

Alps Power Pty Ltd

Customer Service Mailbox: service@alpspower.com.au

Telephone: +612 8005 6688

Address: 14/47-51 Lorraine St Peakhurst NSW 2210

Europe

EFT-Systems GmbH

Customer Service Mailbox: service@eft-systems.de

Telephone: +49 9352 8523999

Website: www.eft-systems.de

UK

Storing Renewable Energy

Customer Service Mailbox: info@srenergy.co.uk

Telephone: +44 (0) 2037695998

Website: www.srenergy.co.uk