



Red

User Manual

RX SERIES ALL IN ONE

2505 PU

dx



All Rights Reserved

No part of this document can be reproduced in any form or by any means without the prior written permission of Redx.

Trademarks



and other Redx trademarks used in this manual are owned by Redx
All other trademarks or registered trademarks mentioned in this document are owned by their respective owners.

Software Licenses

It is prohibited to use data confirmed in firmware or software developed by Redx, in part or in full, for commercial purposes by any means.

It is prohibited to perform reverse engineering, cracking, or any other operations that compromise the original program design of the software developed by Redx.

Contact Us

Redx Technology Australia Pty Ltd

Address: U2 /21 Millennium Circuit, Helensvale, Australia 4212

Tel: +61 7 5672 9983

Email: info@redxenergy.com.au

Website: www.redxenergy.com.au

About This Manual

This manual mainly describes the product information, installation, operation, and maintenance guidelines of the Redx energy storage system. Please read this manual carefully before using this product and store the manual in a safe place. Redx will not notify the user of any changes to this manual.

This manual applies to the RX-2505PU all in one energy storage integrated system. The system must be installed by a qualified/licensed technician. The battery chemistry in the all-in-one energy storage system is lithium iron phosphate. We strongly recommend that installers read this manual carefully. The manual includes the guidance on product installation, troubleshooting, communication and other aspects.

Contents

1 Safety	6
1.1 Important Safety instructions	6
2 Product Introduction	8
2.1 System diagram	8
2.2 Product Information	9
2.3 LED Indicator Panel and Switches	11
2.4 Name Plate Labelling	12
2.5 Product benefits	12
2.6 Scope of Delivery	13
2.7 Storage	13
3 Installation	14
3.1 Installation preparation	14
3.2 Installation Tools	15
4 Installation guide	16
4.1 System wiring diagram	16
4.2 Installation procedure	17
4.3 Earth Connection	17
5 Cable Connection	18
5.1 Connect cables to the AC grid side and off-grid side	18
5.2 CT/METER Connection	19
5.3 External RS 485 Connection	20
6 Operation	21
6.1 Check list before operation	21
6.2 Operation	21
6.3 Operation modes	22
6.4 Communication	23
7 RX-2505PU System turn on and turn off	23
7.1 Turn on RX-2505PU system	23
7.2 Turn off RX-2505PU system	23
8 Troubleshooting & Maintenance	23
8.1 Troubleshooting	23
8.2 Maintenance	26
8.3 Routine Maintenance	26
9 Redx iCloud App	26
10 Quality Assurance	27
11 Appendix	27
11.1 Product Specification	27
11.2 Optional accessories	29
12 Contact	30

1 Safety

1.1 Important Safety instructions

The Energy storage system has been designed and tested strictly according to international safety regulations. Read all safety instructions carefully prior to any work and always observe them when working with the energy storage system.

Incorrect Operation or Work may cause:

- Injury or death to the operator or third party; or
- Damage to the inverter and other property or third party.

Safety Instructions

- a) Do not open the case as risk of electric shock is present
- b) Maintenance should be carried out by a professional licensed technician
- c) Read this manual before operating the system. Redx is not responsible for failure or loss arising out of improper operation.
- d) All wiring, installation, commissioning, and other work should be done by a licensed technician
- e) Ensure that the storage unit is not installed or used in the following locations:
 - Poorly ventilated room
 - Places with inflammable gases or corrosive materials and large amounts of dust
 - High or low Environment temperature (above 50°C or below 0°C), or high humidity (greater than 90%)
 - In direct sunlight or near heating equipment
 - Outdoors (indoor installation only)
 - Do not use anything to cover the inlet and exhaust of the module

In case of fire, use dry powder fire extinguishers instead of liquid fire extinguishers

All electrical connections are subject to the local grid safety regulations and the storage system should be reconnected to the grid under conditions of approval.

Table 1-1 - Warnings











	<p style="text-align: center;">Danger!</p> <p>Removal of any protection, incorrect use, incorrect installation, or incorrect operation may result in death/serious personal injury or device damage. Transportation, loading and unloading, installation, start-up and maintenance must be carried out by qualified or trained engineer/technician.</p>
 	<p style="text-align: center;">Danger!</p> <p>Before maintenance or touching any parts, or installation, make sure that the energy storage unit is disconnected and wait 60 seconds to ensure that the internal capacitor is discharged.</p>
	<p style="text-align: center;">Danger!</p> <p>Do not connect the N of grid to the N of UPS output, Do not connect the grid cable to the UPS output, otherwise it may cause serious damage to the system and load.</p>
	<p style="text-align: center;">Warning!</p> <p>Installation must be in full compliance with national and local laws and regulations.</p>
	<p style="text-align: center;">Warning!</p> <p>Ensure that the system is positioned correctly and is not allowed to roll sideways or upside down.</p>
	<p style="text-align: center;">Warning!</p> <p>Do not change the internal circuit of the machine without permission.</p>
	<p style="text-align: center;">Warning!</p> <p>Before connecting to the grid, system the must be connected to the Ground. Follow the instructions. Improper operation may cause serious damage.</p>
	<p style="text-align: center;">Notice</p> <p>There is a 4G/WIFI device inside the system, do not place the system in an environment where there is no 4G/WIFI signal.</p>

Table 1-2 - Warnings continued

	Warning!
	Product should not be installed in multiple phase combinations
	Warning!
	<p>The load capacity of the output of the inverter is as follows:</p> <p>Inductive load (such as air conditioning, washing machine, motor, etc.) : Single maximum power 1.5kVA, total inductive load maximum power 2.5kVA (with grid power);</p> <p>Capacitive load (e.g. computer, switching power supply, etc.) : The maximum power of the total capacitive load is 1.5kVA (without grid power); The maximum power of the total capacitive load is 2.5kVA (with grid power).</p>

2 Product Introduction

2.1 System diagram

The RX-2505PU system uses the grid and battery to ensure the continuous power supply of important loads. The system allows users to store the energy from grid into the battery. It can also provide backup power during the power outage

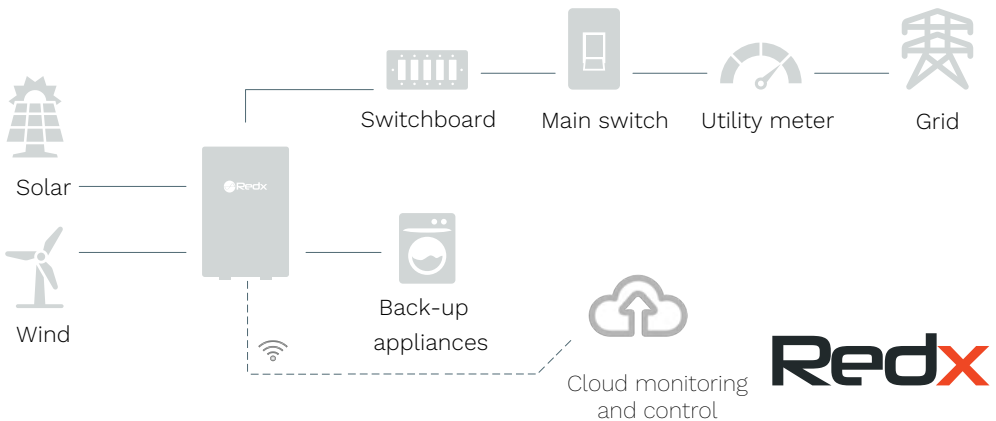

Figure 2-1 - System block diagram

Figure 2-1 shows the application of the RX-2505PU all-in-one uninterruptible power system. RX-2505PU contains inverter and battery storage modules. It is important to keep the installation environment well ventilated and take necessary measures to control the ambient temperature to avoid the risk of explosion caused by excessive battery temperature

2.2 Product Information

2.2.1 Appearance and dimensions

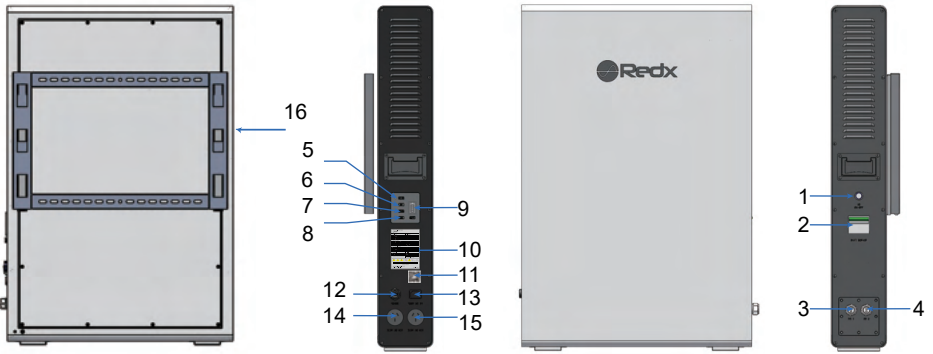

Figure 2-2 - Battery system components

Table 2-1 - Battery components details

Items	Name
1	Main power switch
2	Battery air circuit-breaker
3	DC1 input
4	DC2 input
5	AC-ON Indicator light
6	DC Indicator light
7	Grid Indicator light
8	Charge Indicator light
9	Battery status
10	Nameplate
11	Datalogger QR code
12	USB(RS485)
13	230AC IN
14	230AC OUT
15	230AC OUT
16	Mounting bracket

2.2.2 Dimension and weight

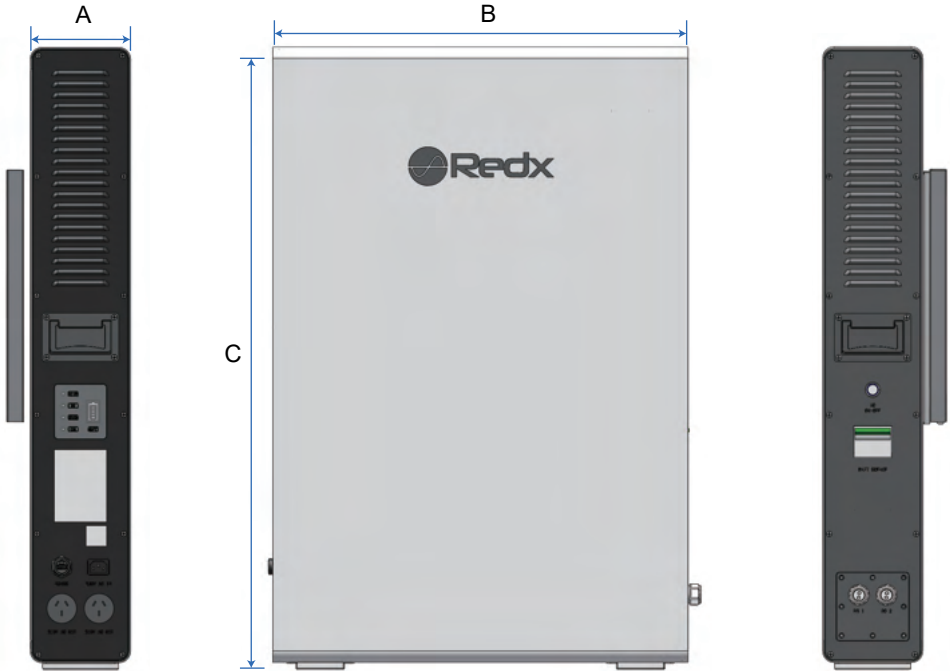



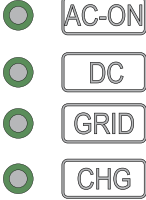

Figure 2-3 - Battery system components

Table 2-2 - Battery system dimensions details

A (mm)	B (mm)	C (mm)	Weight
145	600	900	75KG

2.3 LED Indicator Panel and Switches

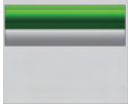

Table 2-3 - Battery interface details

Items	Name	Function	
 <p>AC ON - OFF</p>	Switch button	Turn on/off the system	
	Operating status	AC-ON	Run – Green Fault – Red
		DC	DC1 > 100W – Green (Flash) DC2 > 100W – Blue (Flash) DC1&DC2 > 100W – Yellow (Flash) DC1&DC2 < 100W – LED off
		GRID	Grid connected – Green Grid disconnected – Blue
		CHG	Charging – Green Discharging – Blue
	SOC	Battery status	
 <p>BATT BREAKER</p>	Battery circuit-breaker	Air circuit-breaker between battery and inverter	

2.4 Name Plate Labelling

RX-2505PU label contains the following information.

Table 2-4- Battery label specifications

Uninterruptible Power System	
	
RX-2505PU	
Model Name	RX-2505PU
AC Input Data	
Nominal Voltage	230Vac
Rated Input Current	10A
Nominal Frequency	50Hz
UPS Output Data	
Nominal AC Output Voltage	230Vac
Nominal AC Output Frequency	50Hz
Rated Output Current	5.0A / 5.0A
Power Factor Range	> 0.9
DC 1 / DC 2 Input Data	
Input Current (Max)	25A / 25A
Nominal Voltage	48V
Others	
Battery Capacity	4800Wh
Safety Level	Class I
Ingress Protection	IP32
Topology	Isolated
Operation Ambient Temperature	Charge: 0 C ~50 C
	Discharge: -20 C ~50 C
	



2.5 Product Benefits

- Backup power supply, asset management
- Integrated design, save installation time and costs
- Smart management, different operating modes
- Battery safety management system
- Remote scheduling, intelligent management
- Multiple protection

2.6 Scope of Delivery

Please check the condition of the packing before unpacking. If any parts are damaged or missing, contact your local supplier for help.

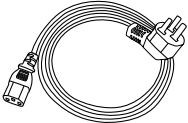
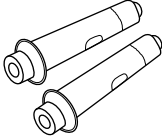
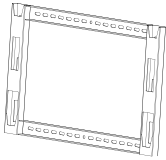
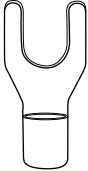
Table 2-4 - Parts in the box

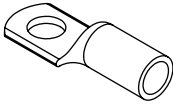
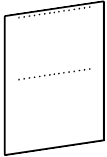
			
RX-2505PU	Power cord	M6	Mounting bracket
1PCS	1PCS	6PCS	1PCS
			
M4	Document	M5	Hole template
5PCS	1PCS	1PCS	1PCS

2.7 Storage

Store the storage unit properly when the unit is not installed immediately

- Store the unit in the original packaging box
- Package dimensions 1025x755x330(mm), weight 101.5kg.
- Maximum stacking 5 pallets
- The storage temperature is as follows

Storage temperature	-20 C ~ 45 C	Less than ① month
	15 C ~ 35 C	Less than ⑥ months



Figure 2-4 - Battery system dimensions details

3 Installation

3.1 Installation preparation

- a. Indoor installation only, IP32
- b. Vertically mount only
- c. Install in a ventilated location. There must be enough clearance to ensure that the module operates in the optimal heat dissipation state.
- d. Install at suitable distance from any restricted areas, please review Standard ASNZS5139
- e. Install on a sturdy support surface
- f. The location must support the weight and size of the module
- g. The environmental temperature must be between 0°C and +50°C, and the relative humidity between 0% and 90% (without condensation)
- h. Check the fans in the unit regularly
- i. Location shall be dry with adequate air flow (pollution level < 2) and without excessive dust
- j. Wiring terminals require protective covers
- k. Installation is prohibited in any of the following environments

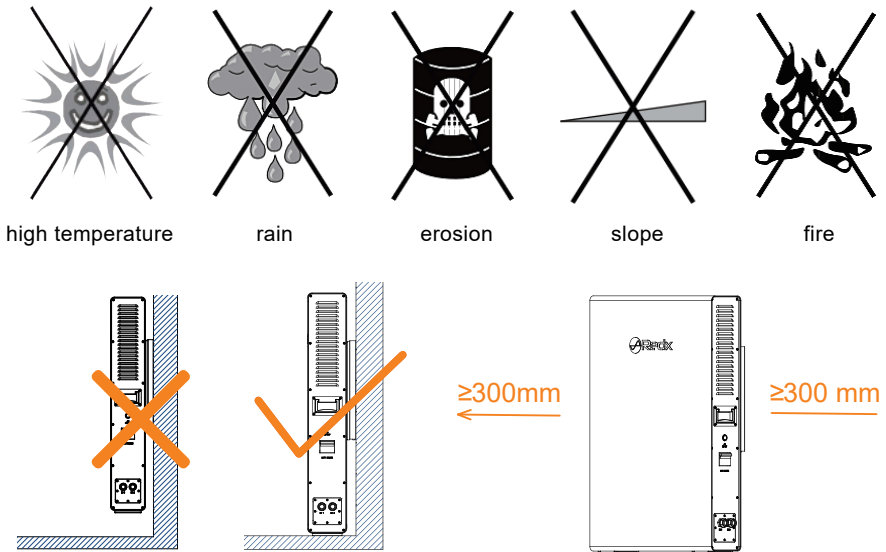

Figure 3-1 - Installation locations

























The minimum clearance between sides must be maintained at least 300mm

- a. Installation location of the system should be easy for operator to turn off at any time;
- b. Do not install the system near signal transmitter;
- c. Do not install the system in the living area;
- d. Do not install the system at location where children can easily access

3.2 Installation Tools

Prepare the following tools before installation

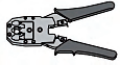
Table 3-1 - Installation tools

Type	Tool			
General tools	 Packaging tape	 Marker	 Measuring tape	 Level
	 Utility knife	 Multimeter Measurement range: $\geq 1100\text{Vdc}$	 Protective clothing	 Wrist strap
	 Protective gloves	 Dust mask	 Earplugs	 Goggles
	 Insulated shoes	 Vacuum cleaner		
Installation tools	 Hammer drill bit	 Rubber mallet	 Slotted screwdriver	 Phillips screwdriver Specification: M4, M6
	 Wire stripper	 hydraulic clamp	 Crimping pliers	 Wire nippers
	 Crystal head crimping pliers	 Percussion drill		

4 Installation guide

4.1 System wiring diagram

Figure 4-1 shows the wiring diagram of the RX-2505PU all-in-one uninterrupted power system. (Only DC1 and DC2 require hardwiring)

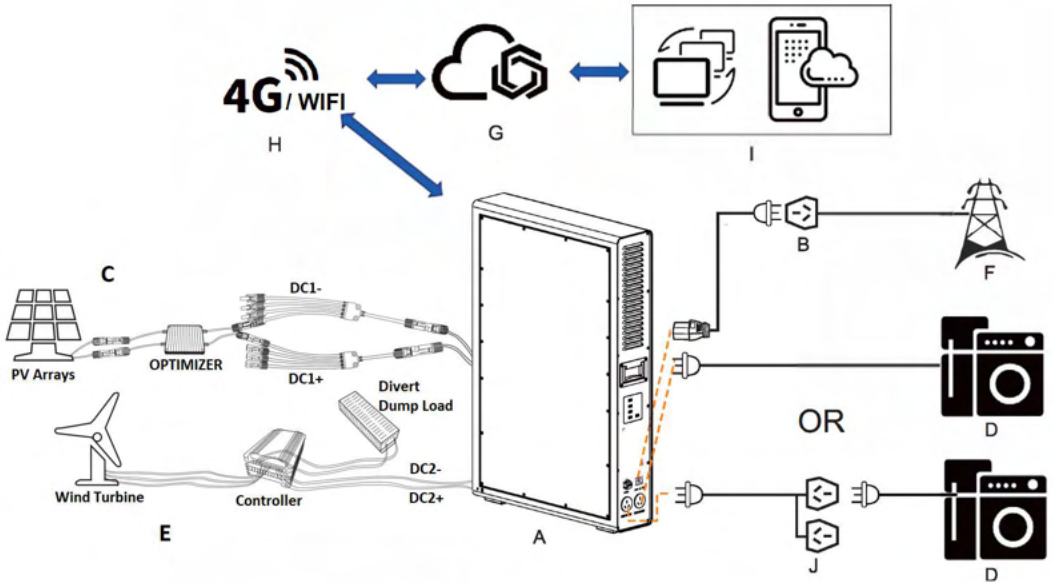

Figure 4-1 - Battery system connections topology

Table 4-1 - Battery connections details

Number	Name
A	RX-2505PU
B	Powerpoint
C	PV Array with Optimizers
D	Load
E	Wind Turbine with Controller and dump load
F	Grid
G	Cloud Server
H	4G / WiFi Connection
I	APP / Software
J	Powerpoint extension

4.2 Installation procedure

1. Align the hole template (locating plate) with the ground and stick it flat on the wall.
2. Align the hole template on the installation surface and drill holes with a diameter of 8mm and a depth of 40mm on the wall.
3. Install the m6x60 expansion screws into the previously drilled holes.
4. Secure fixing bracket to the wall using a socket wrench and tighten the expansion screws.
5. Align the unit with the fixing bracket on the wall and lift the unit on to the bracket by lowering it into the holes.
6. Prepare the unit for installation of cabling

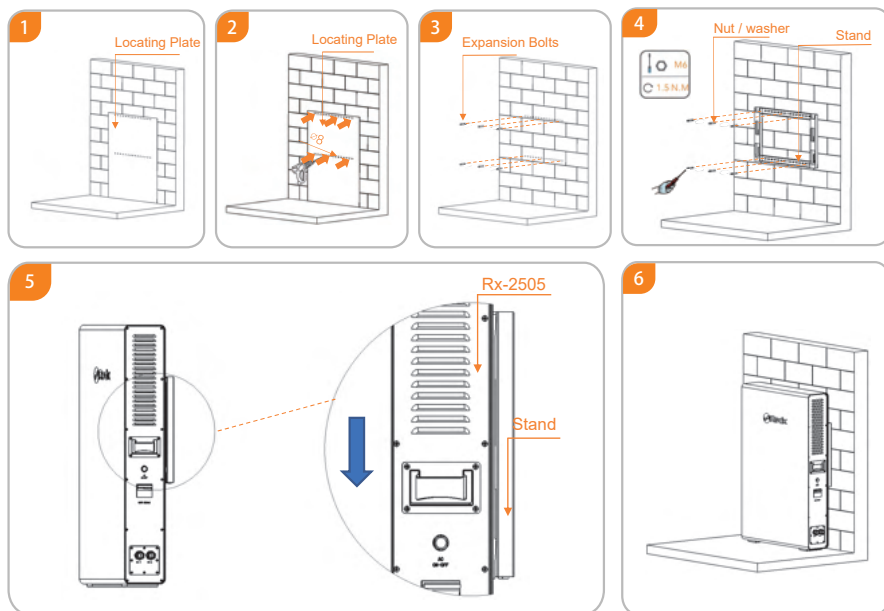

Figure 4-2 - Battery unit mounting steps

4.3 Earth Connection

A secondary protection grounding terminal can be found on the system. Ensure that the grounding resistance is less than 10 Ω and the grounding cable diameter is not greater than 10mm².

5 Cable Connection

5.1 Connect cables to the AC grid side and off-grid side

RX-2505PU has terminals for on/off-grid. As shown in Figure 5-1, RX-2505PU has two AC output ports and one grid power input port. An independent AC circuit breaker must be configured for each system to safely disconnect the connected systems.



The "230V AC IN" port has a plug which must be inserted into the "230V AC IN" port when no grid power is supplied to the unit.

Engineers should refer to local standards to select cables. Cable length is generally 2 to 10 meters, long cable will lead to voltage deviation from the rated value, consequently increasing the cross-sectional area.

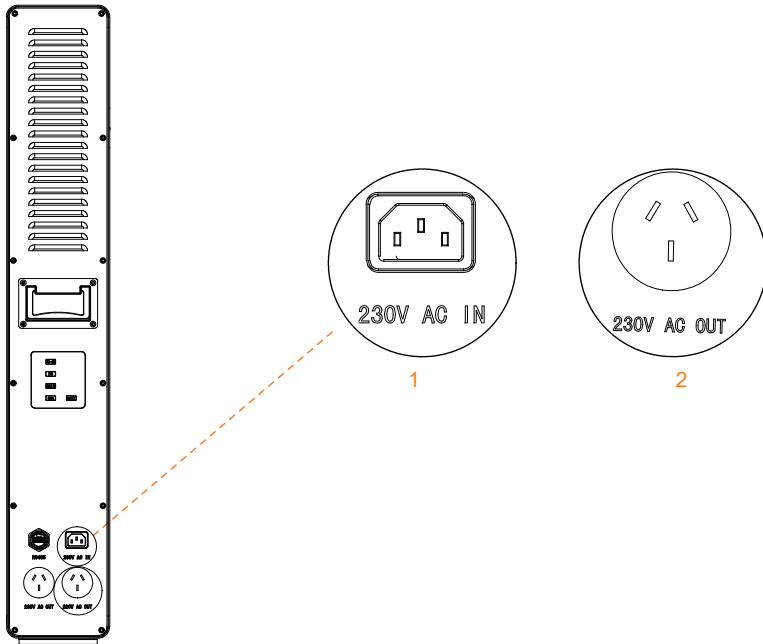

Figure 5-1 - Battery 240V terminals

- ① The maximum load current shall not exceed 10A
- ② The rated current of single output terminal shall not exceed 5A, The total current shall not exceed 10A

Requirements

1. Ensure an AC circuit breaker is installed between the inverter and the grid before connecting the system to the grid.
2. Grid voltage and grid frequency should be within the allowable range of inverter operation.

5.2 Connect cables to DC1 and DC2

1. Connect the cable to the corresponding terminal according to the mark and tighten the screws.

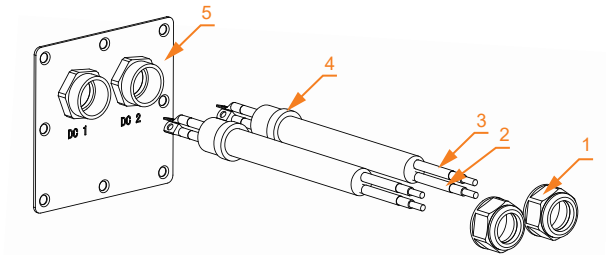

Figure 5-2 - DC Cable cover guide

Table 5-1 - Cable and cover details

1	2	3	4	5
Nuts	DC2+	DC2-	Rubber grommet	Cover

2. The following table lists the parameters of DC1/DC2 cables.

Table 5-2 - Cable parameters

	Nominal Voltage	Input Current
DC1/DC2	48V	25A/25A

The recommended connection is as follows:

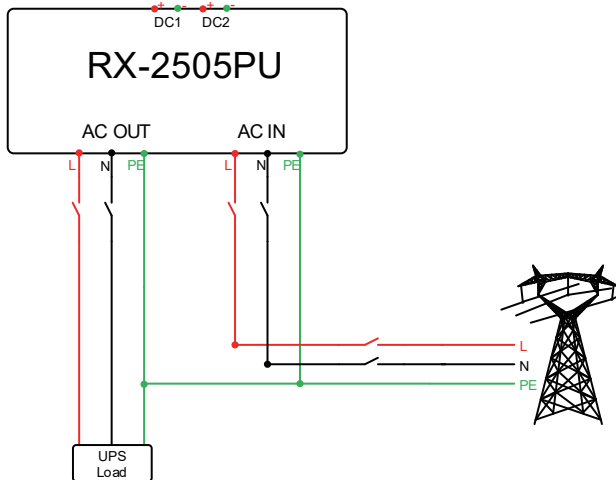

Figure 5-3 - 240V connection diagram

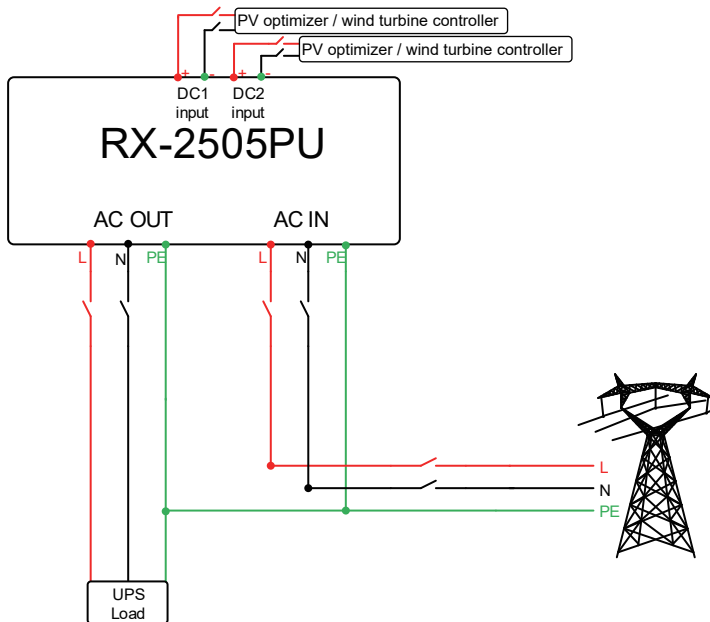

Figure 5-4 - 240V and DC connections

Notice:



1. The grid terminal and off-grid terminal cannot be directly connected together, otherwise the system will be damaged.
2. The off-grid terminal cannot be connected to the grid, otherwise the system will be damaged.
3. The battery needs to be activated by the grid when the system starts for the first time.
4. The UPS Load on-off switch in Figure 5-3 and Figure 5-4 can be installed by customers according to their own needs.
5. The customer can use an external RCD if it is required, the unit does not have an in-built RCD.
6. The maximum current of the AC OUT is 10A (The maximum power of the AC OUT is 2500W).
7. Either the DC1 and DC2 can be connected to solar panels or wind power generator via optimizers/ controllers. The maximum current of the DC1 and DC2 inputs is 25A (each), It is recommended that the output voltage of photovoltaic optimizer and wind turbine controller be set to 51.5v

5.3 External RS 485 Connection

RX-2505PU has an USB RS 485 port allowing customers to connect their own devices.

1. Unscrew the rubber nut on the water-proof cover of the system (RS485);
2. The detail of the USB RS 485 as shown in Figure 5-5;

Note: The RX-2505PU has a Wi-Fi module inside. If customers use another Wi-Fi module or other communication module, they need use the default USB RS 485 port.

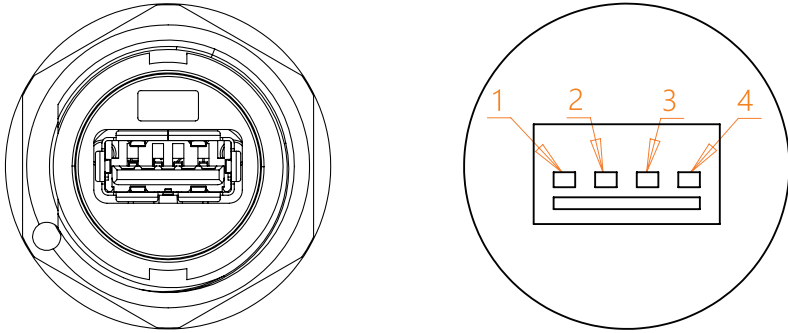

Figure 5-5 - RS485 pins

Table 5-3 - RS485 pins details

1	2	3	4
+5V	485_A	485_B	GND

6 Operation

6.1 Checklist before operation

1. Check whether the system is firmly installed, and the installation position is suitable for operation and maintenance.
2. All cables are correctly connected, properly distributed, and well protected, and no mechanical damage is caused.
3. The selection of AC circuit breakers is correct.
4. The wiring terminals are securely installed, and the vacant terminals are sealed.
5. All safety signs and warning labels on the system are firmly and clearly visible

6.2 Operation

1. Confirm that the above check list meets the guideline
 2. Turn on the AC circuit breaker
 3. After the AC circuit breaker is turned on and the LED on the system is on, perform the following operations
 - a) If the blue power LED does not light up, check if the grid power cable is tightly inserted. If the grid power cable is OK and tightly inserted, but unit is still not illuminating the power button - please contact local Redx dealer.
 - b) Install the APP or open web page according to the attached instructions, and then configure the WIFI connection.
 - c) Turn on the battery circuit breaker on the side of the system.
 - d) Press the power button on the side of the system, then the system is in bypass state and UPS port has output.
 - e) Send charging command through the web or APP. The battery LED indicator on the panel lights up, and the other LED indicators will light up according to the actual working status.
 - f) If the operation fails, troubleshoot the fault by referring to Chapter 9 in this manual.
- Note:** Use the grid and the APP to activate the battery for the first-time operation.

6.3 Operation modes

6.3.1 Normal UPS mode

When the power grid is cut off, the system will automatically switch to off-grid mode. The system will supply power to the load through the battery. Note: under off-grid mode, the system power output rate is 2500W. The load power rate of the UPS end should not exceed 2500W.

When the system detects a low battery status, the battery will stop discharging automatically and will be charged if there is solar or other power supply.

6.3.2 Fault state

The RX-2505PU has a smart control system that continuously monitors and regulates system status. When there is a system fault or equipment fault, fault information will be displayed on the web page /APP, and the LED light will also be on in fault mode.

Notes:

A) For details about fault information, see Chapter 9.

B) Part of the fault information is used to remind users of possible internal fault of the system

6.3.3 Firmware update

When the system is upgrading firmware, do not power off. When the upgrade is complete, the system will automatically switch to normal working mode.

6.3.4 Self-check Status

Before entering normal operation mode, RX-2505PU will enter self-check mode. If all goes well, the system will return to normal working mode; otherwise, the system turns to the fault state.

6.3.5 Standby Status

When the system does not fault but certain operating conditions are not met, the system will turn to standby mode.

6.3.6 Protection Mode

Connecting an over size load to the UPS terminal will trip the unit and trigger protection mode. The unit will try to restart 3 times, if the load is still present, the unit will revert to protection mode. Remove the over size load and restart the unit. If any circuit breakers have tripped – contact your installation partner.

6.3.7 Shutdown Status

Disconnect all power supply and the system will automatically convert to shutdown mode.

To shut down the unit, follow the specific steps below:

1. Turn off the the power button
2. Turn off the battery switch
3. Disconnect the grid supply, the LED light and the battery power display LED light will be turned off.

Note: After all the above steps are completed, wait at least 5 minutes before performing other operations

6.4 Communication

The system has an external USB interface, which contains 5V power supply and RS485 communication. Redx also has a built-in data collector. Users can choose to connect their own data collector (WIFI/GPRS function) according to their requirements, and use the computer or mobile phone APP to monitor the machine.

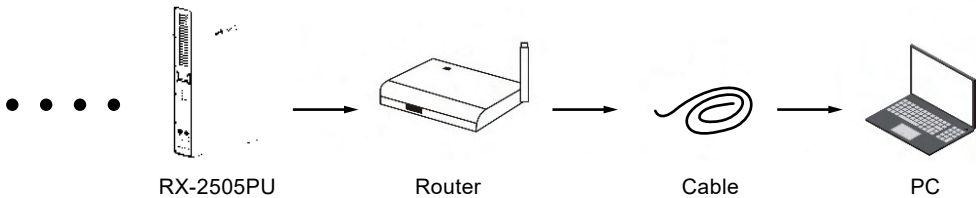

Figure 6-1 - Network diagram

7 RX-2505PU System turn on and turn off

7.1 Turn on RX-2505PU system

You can perform the following steps to start the RX-2505PU:

- 1) Connect to the grid
- 2) Turn on the battery circuit breaker
- 3) Turn on the power button
- 4) When the LED display is normal, the system starts normally.

7.2 Turn off RX-2505PU system

You can perform the following steps to start the RX-2505PU:

- 1) Turn the unit off from the power button
- 2) Turn off the battery circuit breaker
- 3) Turn off the AC circuit breaker
- 4) When the LED display is off, the system is completely off

8 Troubleshooting & Maintenance

8.1 Troubleshooting

Once a fault occurs in the storage unit, the fault information can be displayed on the APP/web interface.

Common Fault and Information below:

Table 8-1 - Fault information table 1



Fault information	Fault reason	Suggestion
The battery connection error	No battery is detected	If the battery is connected 1. Check whether the battery cable is securely connected and whether the battery voltage is normal. 2. If the error message remains, contact installation partner.
Battery under voltage or over voltage	If the battery voltage is abnormal, the internal circuit protection is triggered	1. Check whether the battery is correctly connected and whether the battery voltage is normal 2. Make sure the battery is in good condition and restart the module 3. If the error message remains, contact installation partner.
No grid	No grid is detected	If the grid is connected 1. Check whether the grid connection line is firmly connected and the grid voltage is normal; 2. If the error message remains, contact installation partner
DC Bus under-voltage	The input is suddenly disconnected	1. When the fault is recovered, the inverter will automatically return to normal working state; 2. If the external environment does not change and the alarm remains after the system is restarted, contact installation partner.
DC Bus over-voltage	The rapid change of power grid voltage may cause high energy input to the inverter. Internal dc-dc converter or charging electronics may have a fault.	1. After the fault error is recovered, the inverter automatically restores to the normal working state. 2. If the fault remains, contact installation partner.
Inverter overvoltage	The output voltage of the inverter is out of the range.	1. Check whether the external load exceeds the specification range of the inverter. After the fault is recovered, the inverter automatically recovers to the normal working state. 2. If the alarm is repeated, contact installation partner.
Inverter undervoltage		
Grid overvoltage	When the grid detects an error, the inverter	1. Check the grid voltage or frequency; If the power grid voltage or frequency exceeds the allowable
Grid undervoltage		

Table 8-2 - Fault information table 2

Grid over frequency	automatically switches to the off-grid mode. When the error disappears, the inverter automatically resumes to the grid mode	range of converter protection parameters, please report to the power grid company.
Grid underfrequency		2. If the power grid voltage or frequency is within the permissible range, contact the installation partner.
Battery over current	The charge and discharge current of the battery is too high	<ol style="list-style-type: none"> 1. Check whether the battery voltage and capacity exceed the allowable range of the inverter. 2. If the alarm is repeated, contact installation partner.
Relay fault	Detect the fault of relay	<ol style="list-style-type: none"> 1. Wait for the inverter to recover automatically. 2. If the alarm is repeated, contact installation partner.
Bus soft start failed	Bus voltage setup timeout	<ol style="list-style-type: none"> 1. Wait for the inverter to recover automatically. 2. If the alarm is repeated, contact installation partner.
The inverter soft start failed	Inverter output setup timeout	
EEPROM read failure	EEPROM read fault	<ol style="list-style-type: none"> 1. Disconnect power and restart the system ; 2. If the error remains, contact installation partner.
Fan fault	The fan is faulty	<ol style="list-style-type: none"> 1. Check whether the fan runs properly. Power off to restart the module; 2. If the error message still exists, contact installation partner.
Output overload	Overload	<ol style="list-style-type: none"> 1. Remove some loads. Ensure that the load is smaller than the maximum output power of the inverter. 2. Restart the inverter
Components over temperature	<ol style="list-style-type: none"> 1. The inverter installation location is not ventilated. 2. The ambient temperature is too high. 3. The fan is faulty. 	<ol style="list-style-type: none"> 1. Check whether the operating environment exceeds the operating temperature range of the inverter. If yes, improve the operating environment. 2. Check whether the fan is in good condition
The communication between the host computer is error	<ol style="list-style-type: none"> 1. The address and baud rate are incorrectly set. 2. The communication cable is loose 	<ol style="list-style-type: none"> 1. Check the communication address and baud rate Settings (please change the baud rate to 2400); 2. Check whether the communication cable is loose. 3. Contact installation partner.
DSP communication error		
Load short circuit	Output short circuit	Output short circuit

8.2 Maintenance

Table 8-3 - Maintenance warnings

	<p style="text-align: center;">Danger!</p> <p>RX-2505PU has lithium battery inside. Please pay attention to the following matters:</p> <ul style="list-style-type: none"> ● Do not place RX-2505PU near fire or any heat source, there may be risk of explosion; ● Do not open RX-2505PU, without permission; ● The battery has the danger of electric shock or short circuit current; ● Battery maintenance is to be performed by service personnel only
	<p style="text-align: center;">Danger!</p> <p>Please read carefully the following items before installation:</p> <p>A) Remove watches, rings or other metallic objects. B) Use tools with insulated handles C) Wear rubber gloves and insulated shoes</p>

8.3 Routine Maintenance

Table 8-4 - Maintenance list

Item	Method	Period
System Clean	Check the temperature and dust off the storage Unit. Clean the unit enclosure if necessary.	Six Months to a year
Cable Entry	Check whether the cable entry is insufficiently sealed or the gap is excessively large; and reseal the entry when necessary.	Once a year
Electrical Connection	Check whether all cables are firmly in place. Check whether a cable is damaged (rodents. physical damage, weather etc)	Once a year

9 Redx Power App

The Redx Power APP can establish communication connection to the energy storage unit via WIFI and or 4G (optional) network. Users can use the APP to view basic information, alarms, events, set parameters, or download logs etc.

Note: Install the APP or open web page according to the attached instructions, and then configure the WIFI connection. The last page of the manual has a QR code to install the App.

10 Quality Assurance

When a product faults during the warranty period. REDX will repair or provide a replacement product.

Evidence

During the warranty period, the customer must keep and provide the product purchase invoice and date. The user must provide proof of fault – pictures or videos with timestamps if requested by Redx. From the date of purchase by the user from Redx (hereinafter referred to as the manufacturer), the user will enjoy the following after-sales warranty service:

1. A 5-year warranty commences from the date of shipment from, during the warranty period the company provides free repair or replacement of product.
2. Any paid service (extended warranty) is available from the date of shipment from manufacturer.
3. Disclaimer: Product faults caused by the following reasons are not within the scope of the manufacturer's 5 years warranty commitment:
 - a) The user does not perform the correct operation according to the procedures listed in the product specification.
 - b) Repairing the product without communicating with the manufacturer or changes the product without permission, resulting in product failure.
 - c) Users not following the standards.
 - d) The fault of the module caused by unsuitable environment.
 - e) Fault due to earthquake, fire, natural disaster, lightning strike, war, solar flare, abnormal voltage rise, ionising radiation or other natural disasters caused by external factors.
 - f) Outdoor installation of the unit will be considered a breach of the manufacturer's warranty.
4. Under the following circumstances, the manufacturer has the right not to provide warranty service:
 - a) Brand, trademark, serial number, nameplate and other marks marked by the manufacturer in the product are damaged or cannot be identified
 - b) The customer fails to pay off the products according to the Purchase and Sales Contract signed by both parties
 - c) The user intentionally concealing the improper use of the product during installation, wiring, operation, maintenance or other processes to the after-sales service provider of the manufacturer

*Redx reserve the right to change the contents of this specification and product performance without informing users.

11 Appendix

11.1 Product Specification

Table 11-1 - Product specifications table 1

Model		RX - 2505PU
Battery Capacity		4.8kWh
Nominal voltage		48Vdc
Voltage range		42Vdc - 54Vdc
Battery type		LFP
Max charging power / current		1500W / 30A
Max discharging current		70A
DOD (%)		90%
Grid		
Nominal grid voltage		230Vac
Grid voltage range		180Vac-260Vac
Rated grid frequency		50 Hz
Grid frequency range		50 ± 5 Hz
Max grid input current		10A
Total THD		< 3%
Phase type		Single Phase
Off - grid (UPS)		
Nominal output power voltage		230 Vac
Nominal output power current		5.0 A / 5.0 A
Power factor		>0.9
Nominal output power frequency		50 Hz
Output short-circuit current		55Apeak@0.1ms;40Arms@5s
DC1 / DC2		
Rated Voltage		48V
Input Current (Max)		25A / 25A
Efficiency		
Max charging efficiency		94%
Max discharging efficiency		96%
System		
IP Rating		IP30
Operating temperature range (charging)		0 C ~ 50 C
Operating temperature range (discharging)		-20 C ~ 50 C
Environment temperature range		-20 C ~ 45 C (one month)
		15 C ~ 35 C (six months)
Relative humidity		10% ~ 100%

Table 11-2 - Product specifications table 2

Cooling	Natural cooling
Acoustic Noise	40dB
Max Altitude	2000m
Inverter topology	No transformer
DC/DC topology	High frequency transformer
Type of supply system on input and output	TN system
Communication	Modbus-RTU/Modbus-TCP, CAN2.0B, TCPIP, WIFI
Communication port	RS485 / CAN/WIFI / GPRS
Weight	75Kg
Dimension (L/W/H)	900mm*600mm*140mm
Warranty	5 Years
Certificates and approvals	IEC-62040-1
Protection	
DC reverse connection protection	YES
AC output short circuit protection	YES
Over frequency and under frequency protection	YES
Over voltage or under voltage protection	YES
DC fuse (battery side)	YES
Overcurrent protection (incl. battery overcurrent)	YES
Over-temperature protection	YES

11.2 Optional accessories

The following table lists the optional accessories of the system, contact the manufacturer or distributor for further information

Table 11-3 - Accessories details

Name	Notes
Data Collector	Data Collector (Wi-Fi)/4G
Raspberry Pi	VPP control
Smart Meter	Single phase smart meter

12 Contact

If you have any questions about our products, please contact our service hotline or dealers. please provide the following information when inquiring:

1. System serial number
2. System model
3. Fault code/Name
4. Briefly describe the fault symptom



For more information, please scan QR code above or log in directly www.redxenergy.com.au



Download the Redx App with the above QR Code

Address: Unit 2/21 Millennium Circuit, Helensvale, QLD Australia 4212

Website: www.redxenergy.com.au

Email: [info @ redxenergy.com.au](mailto:info@redxenergy.com.au)

Phone: +61 7 5672 9983

Specifications are subject to changes without advance notice.

For more information, please scan QR code or log in directly



尺寸：149*210mm

材质/克重/工艺：34P 封面封底157g铜版纸，内页128g铜版纸 正反印 骑马钉