

Step 1  
Mounting bracket

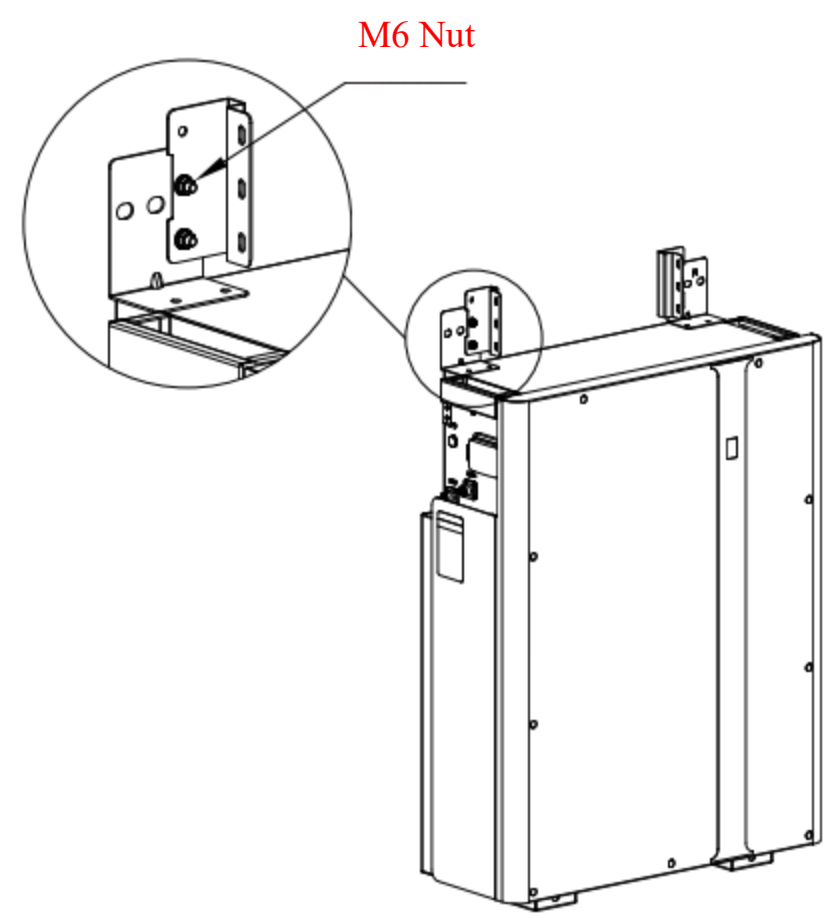

Step 2  
Fixing the expansion box to the bracket

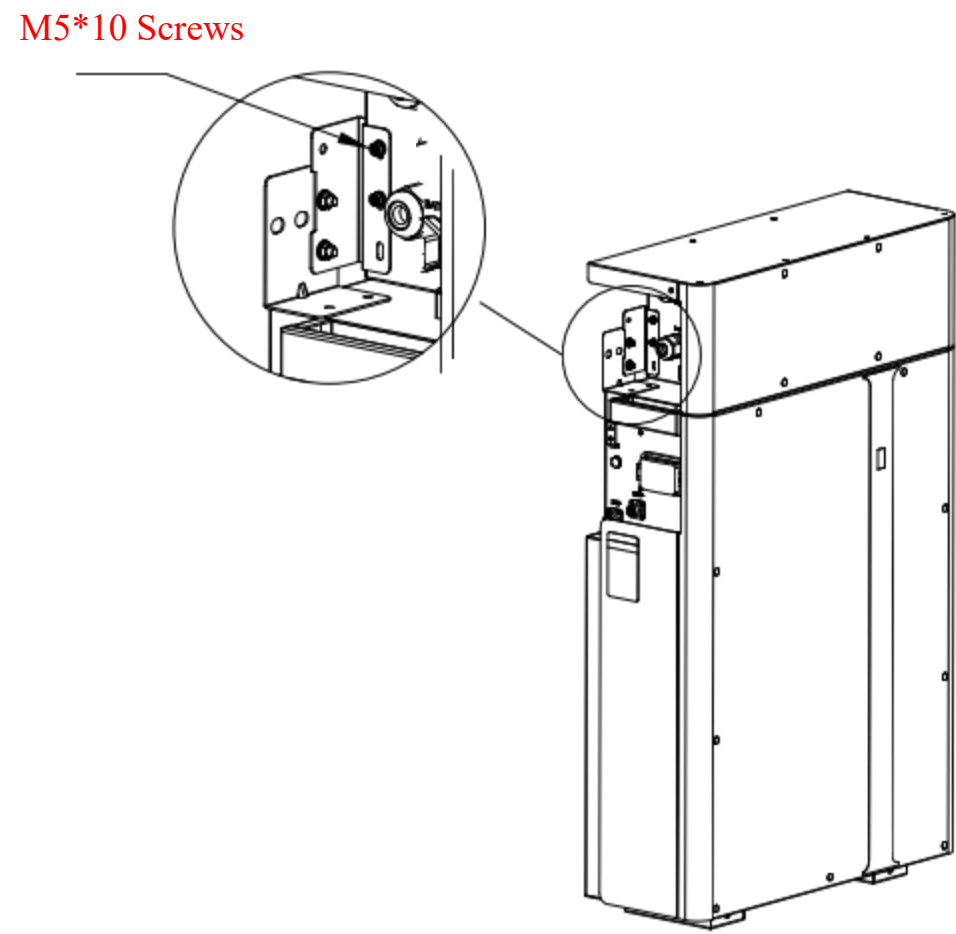

Step 2  
Expansion of one wiring to the right  
(wiring from the back)  
150mm spacing between batteries

The red line is BAT+ power cable  
The green line is BAT- power cable  
Magenta line is BAT communication cable

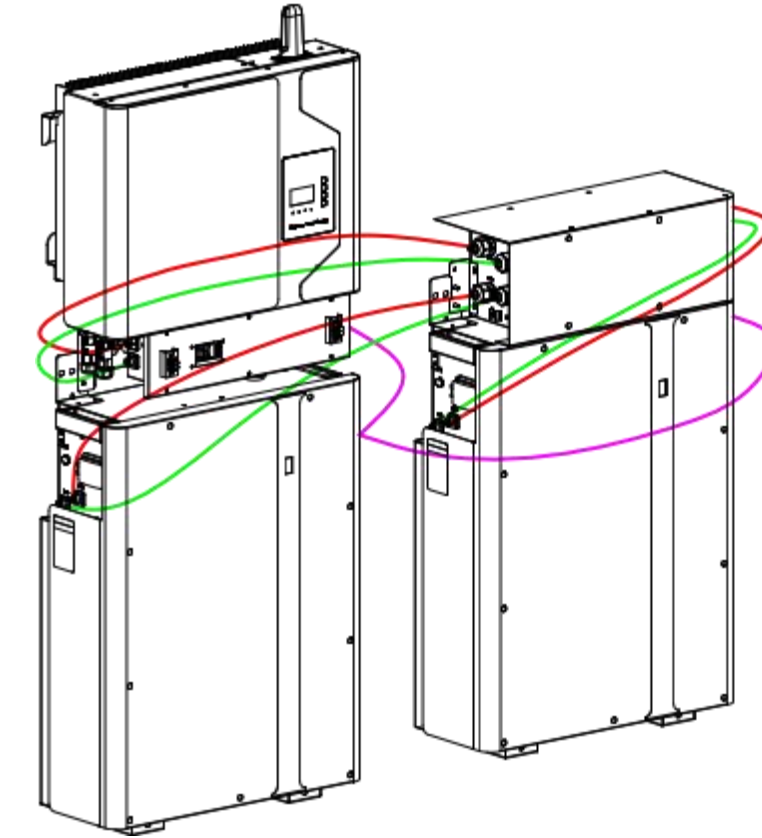

Step 4  
Expansion of two wiring to the right (wiring from the back);  
150mm spacing between batteries;  
The wiring harness on the right side of expansion box A needs to be modified and connected to expansion box B. See Step 5-8 for details.

The red line is BAT+ power cable  
The green line is BAT- power cable  
Magenta line is BAT communication cable

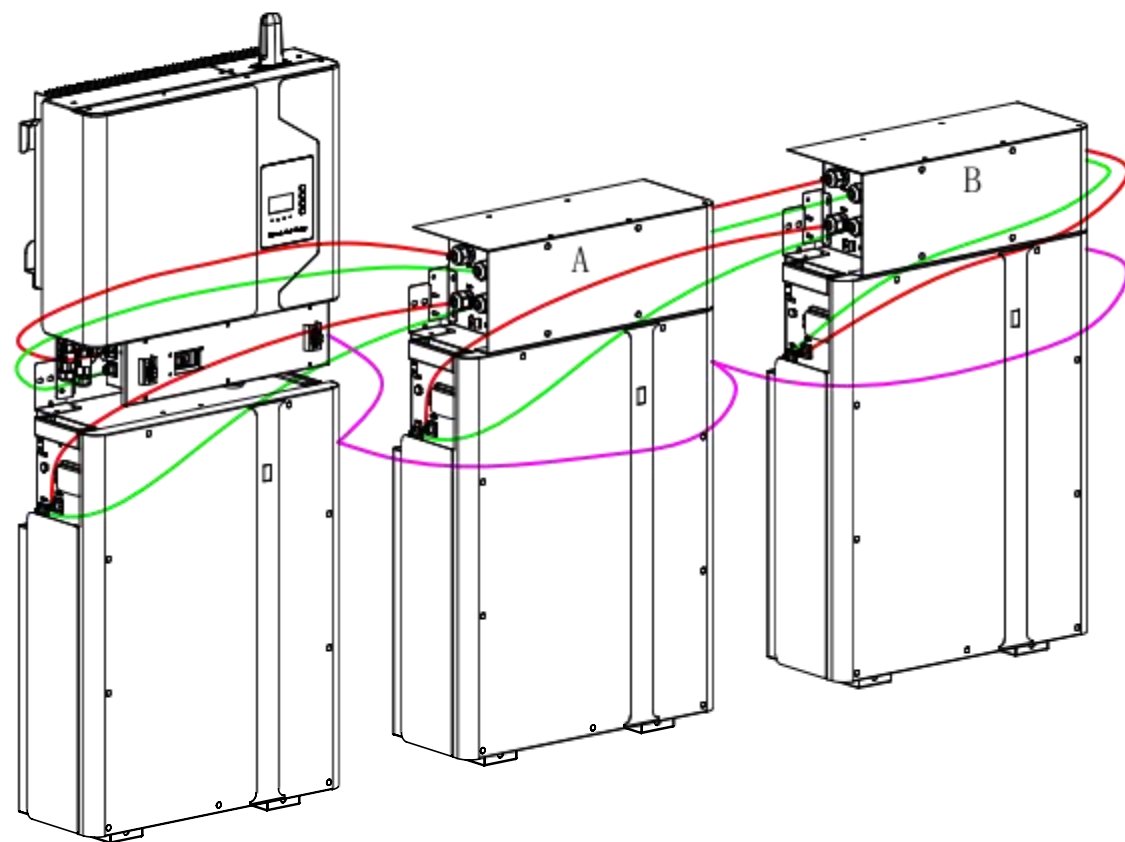

Step 5  
Cut off the Amphenol connector from the harness on the right side of the expansion box A and crimp the SC25-6 metal

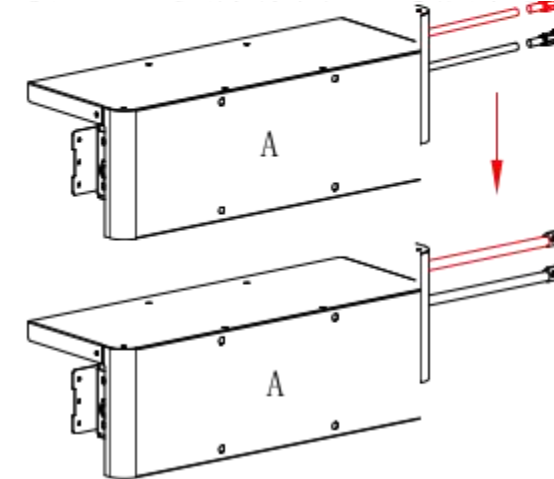

Step 6  
Disassemble the front of the expansion box and a few screws from the top of the box, remove the front cover plate

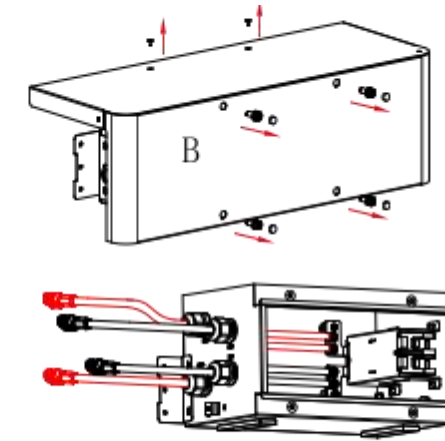

Step 7  
Loosen the tightening head of the waterproof connector at a  
Remove the nut at b  
Pull out the two wire harnesses

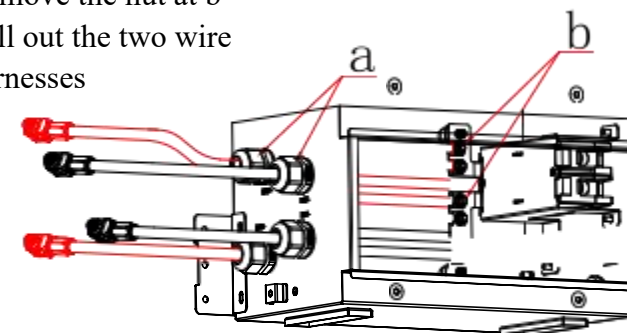

Step 8  
Pass the two wires on the right side of expansion box A through the waterproof connector at a of expansion box B and lock them to the brass plate at b respectively (note the positive and negative poles) and finally fit the front cover to expansion box B

