

Installation & operation Manual

Air – Source Heat Pump Heater



Model Numbers:

WH250A-R

WH250A-RE

WH250A-C

WH250A-CE

Please read the manual carefully before using the product, and properly keep this manual for reference.

Please entrust professionals to install this product.

Dear Users,

Thank you for choosing our water heater. This manual is designed to be your comprehensive guide for the installation, operation, and maintenance of your new appliance. It also contains crucial safety information that is essential for ensuring the reliable and safe performance of the water heater.

Before You Begin:

Please take the time to thoroughly read and familiarize yourself with all the contents of this manual prior to installing and using the water heater. This will not only enhance your understanding of the product but also contribute to a trouble-free experience.

Keep for Future Reference:

We strongly recommend keeping this manual in a safe and easily accessible place for future reference. In the event of maintenance, troubleshooting, or any inquiries, having this manual on hand will be invaluable. It serves as a key resource to assist you in optimizing the performance and lifespan of your water heater.

Your safety and satisfaction are our top priorities. If you have any questions or concerns, please do not hesitate to contact our customer support team.

Table of contents

Safety Precautions.....

Parts and Functions.....

Installation Instructions.....

Pipeline Connection.....

Electrical Connection.....

Usage Methods.....

Operation Instructions.....

Trial Operation.....

Maintenance and Trouble Shooting.....

WIFI Connection.....

Safety Precautions

Prior to using this product, it is imperative that you thoroughly review the "Safety Precautions" chapter in this manual. This section outlines critical safety considerations that must be strictly adhered to. Please adhere to these guidelines diligently to ensure a secure and hazard-free usage experience.

Warning

1. Household electricity must have reliable grounding.
2. Leakage protection devices must be installed for household electricity.
3. Do not remove any permanent instructions, labels, or parameter plates on the casing of the product or inside any plates.
4. The product should be installed on a safety tray when installed indoor.

Warning

1. For installation, rely on authorized dealers or professionals with relevant expertise to prevent potential hazards like fire, electric shock, personal injury, or water leakage due to improper installation.
2. Purchase only company-designated articles if needed for the product.
3. Adhere to local electric company regulations when connecting the power supply.
4. When relocating or reinstalling the hot water machine, entrust the task to authorized dealers or professionals.
5. Never attempt self-modification or repair, as it may result in accidents such as fire, electric shock, personal injury, or water leakage. Always seek the expertise of authorized dealers or professionals for repairs.

Warning

1. Ensure the socket is reliably grounded and kept dry to prevent electricity leakage. Regularly check the plug and socket for a secure fit and replace overheating sockets promptly to prevent fire hazards.
2. Install power sockets in areas where water may splash at a minimum height of 1.8 meters, ensuring they are out of reach of children and away from direct water exposure.
3. Install temperature and pressure safety valves at any cold-water inlet, and if the lowest water point is more than 3 meters below the hot water outlet, install a vacuum breaking valve at the highest point of the water tank.
4. Water drops from the pressure relief hole during heating are normal. If excessive leakage occurs, seek professional repair promptly. Never block the pressure relief hole to prevent water heater damage and safety accidents. Ensure the drainpipe connected to the pressure relief hole is inclined downward and placed in a frost-free environment.
5. Exercise caution with hot water temperatures exceeding 50°C to prevent scalding. When using hot water initially, avoid directing it directly onto the body.
6. If the power cord is damaged, replace it with the manufacturer's professional power cord. Replacement should be performed by the manufacturer, its service agencies, or qualified professional maintenance personnel.
7. For damaged unit parts, send them to professionals for maintenance and use specialized maintenance services provided by our company.

Warning

8. If the water heater is unused for more than 2 weeks, hydrogen, a highly flammable gas, may accumulate in the hot water piping system. Before using any electrical appliances connected to the hot water system, turn on the hot water faucet for a few minutes to reduce the risk. If hydrogen is present, you may hear an abnormal sound when water flows through the pipe. Avoid smoking or using an open flame near the faucet during usage.
9. This appliance is not intended for use by individuals with reduced physical, sensory, or mental capabilities without proper supervision or instruction.
10. Children should be supervised to prevent play with the appliance.
11. The appliance includes an earth connection for functional purposes.
12. For appliances with type Y attachment, a damaged supply cord must be replaced by the manufacturer or qualified persons to avoid hazards.
13. CAUTION: Do not supply this appliance through an external switching device, such as a timer, to prevent inadvertent resetting of the thermal cut-out.
14. Inlet water pressure: Maximum 0.65MPa, Minimum 0.15MPa.
15. Appliances accessible to the public.
16. DANGER: Do not reset the thermal cut-out until serviced by a qualified person.
17. DANGER: Operate the relief valve easing gear at least every six months to prevent water heater explosions. Continuous leakage may indicate a problem.
18. Water may drip from the pressure-relief device; the discharge pipe must be open to the atmosphere, operated regularly, and checked for blockages.
19. Fixed wiring insulation must be protected, e.g., by insulating sleeves with an appropriate temperature rating.
20. Install a pressure reducing valve if water supply pressure exceeds the rated pressure.
21. Provide instructions for the pressure-relief device, discharge pipe installation, and details for closed water heaters with heat exchangers.
22. The water heater is permanently connected to the water mains.
23. The acceptable atypical value for water hardness or total dissolved solids is 600mg/Liter.

Warning

1. Ensure continued safety by installing, operating, and maintaining this appliance according to the manufacturer's instructions.
2. Caution: This appliance may deliver water at high temperatures. Refer to the Plumbing Code of Australia (PCA), local requirements, and installation instructions to determine if additional temperature control is needed.
3. Safety Note: If the hot water system remains unused for two weeks or more, highly flammable hydrogen gas may accumulate. To safely dissipate the gas, turn on a hot tap for several minutes until gas discharge ceases. Use a sink, basin, or bath outlet, avoiding dishwashers.

Attention

1. Do not use a hose-set with this appliance.
2. Install the appliance in accordance with national wiring regulations.
3. The instructions for disconnection in the fixed wiring follow AS/NZS 3000 standards.
4. Install in compliance with Australian plumbing standard AS3500.4.
5. Set the thermostat temperature to 60°C
6. Water operating temperature must be set at 60°C.
7. Water operating pressures should be between 0.15MPa and 0.85MPa.
8. DO NOT Install the power cord with plug outdoors, it's only for indoor use.

Attention

9. The external power box must have an air switch with leakage protection. Ensure reliable grounding before using the machine.

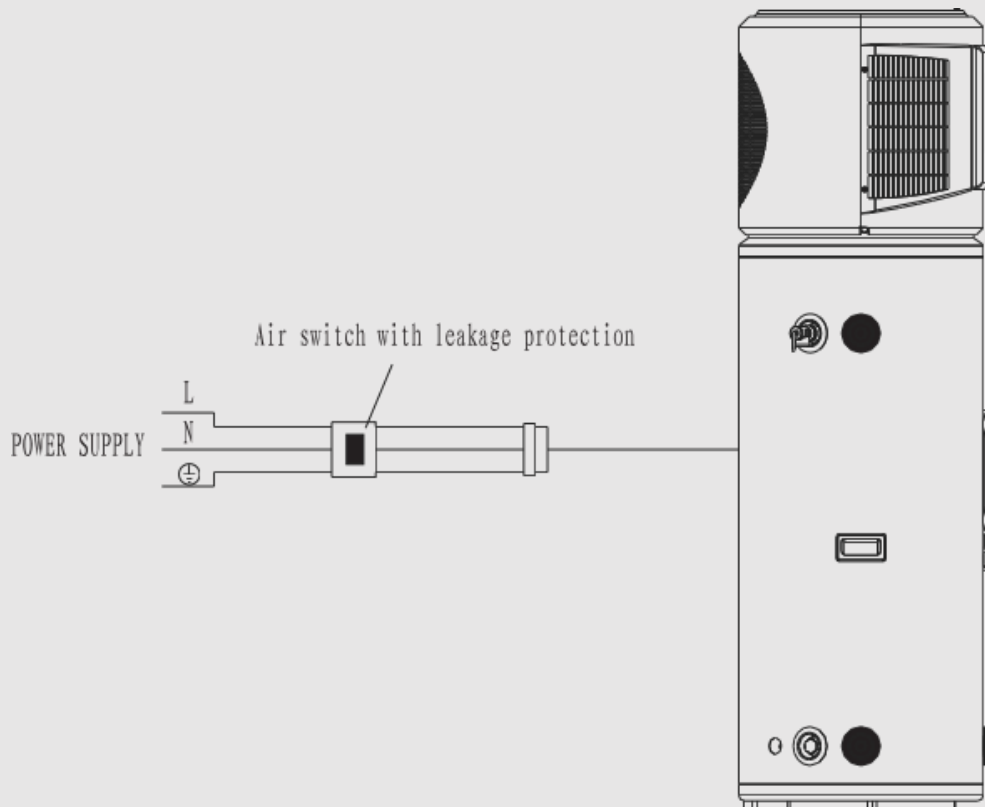

10. In the case where refrigerant filling is required:
- It must be implemented by a qualified technician.
 - Fill according to the type and weight of refrigerant marked on the unit's nameplate.
 - Fill at the check valve of the suction pipe.

Parts and Functions

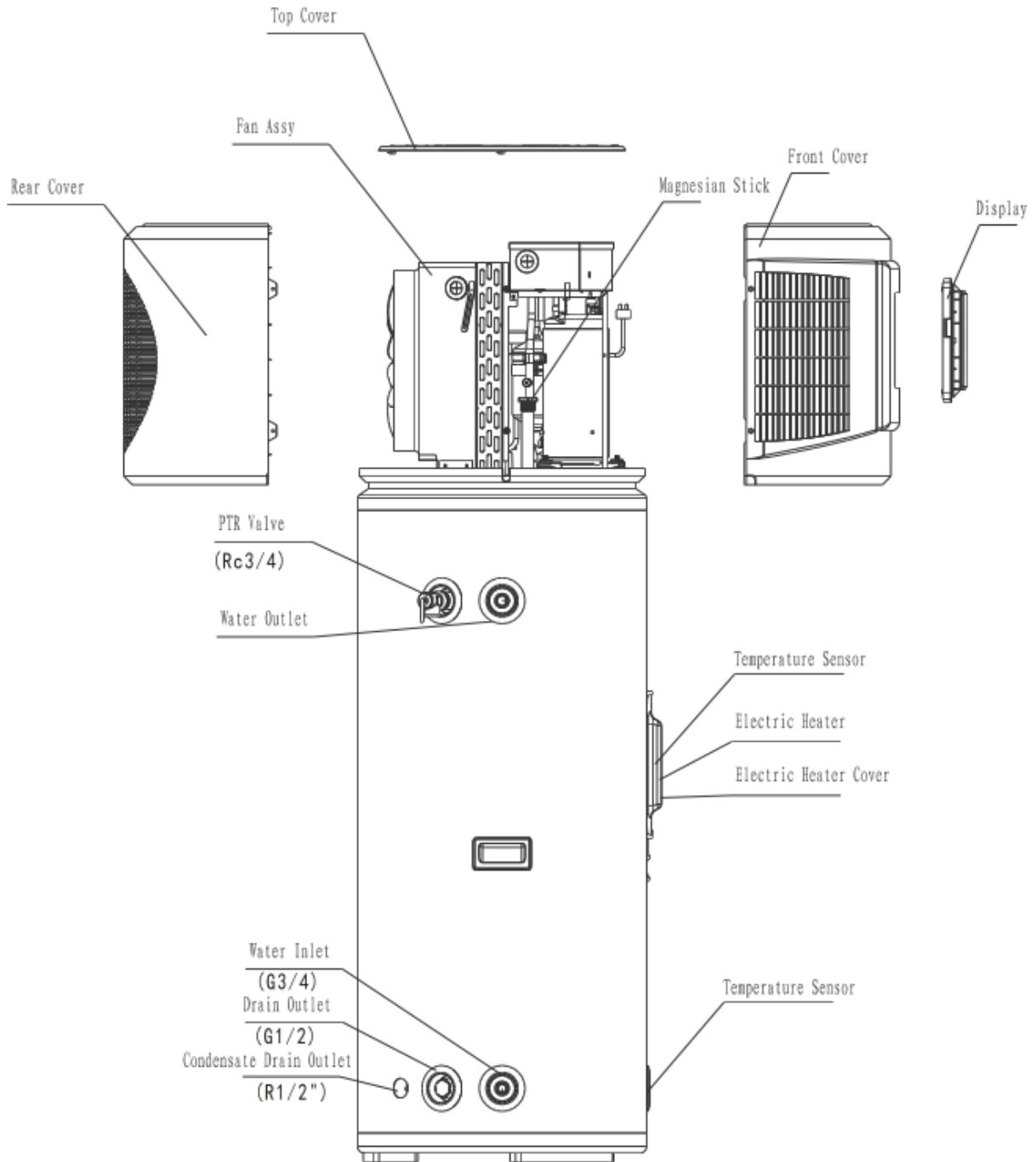

NOTE: This diagram is only for reference, and the appearance of the product may not be the same as that of the real object. Subject to the actual model.

Installation Instructions

Selection of installation site

1. It is advisable not to install this water heater indoors. If installed indoors, issues such as overflow, noise, and a drop in indoor temperature may occur, impacting your daily life. Please take preventive measures in advance.
2. Ensure there is sufficient space for installation and maintenance.
3. Ensure there are no obstacles at the inlet and outlet and no strong winds blowing.
4. Choose a dry and well-ventilated location.
5. The supporting surface should be flat with a horizontal inclination angle not exceeding 2 degrees, capable of bearing the water heater's weight. The unit should be positioned vertically to prevent increased noise and vibration.
6. Ensure that running noise and exhaust air do not disturb neighbors.
7. No risk of combustible gas leakage.
8. Ensure convenient access for pipe and electrical connections.
9. If the water heater is installed on a metal part of the building, ensure proper electrical insulation, adhering to relevant technical specifications for electrical equipment.
10. If the unit is installed in basement, indoor or other confined spaces, pay attention to the circulation of exhaust and intake of air around the indoor and outdoor unit.
11. Please ensure the sufficient space for installation and maintenance:
12. Installation must comply with AS/NZS 3500.4.

Attention

1. In climate where temperature drops below 0°C, it is recommended to install the unit indoors or in locations where freezing can be avoided. This precaution prevents water pipes from cracking, ensuring a more convenient daily life.
2. In climate where temperature drops below 0°C and system is installed outdoor, implement appropriate insulation measures for the water pipes based on local minimum temperatures. Ensure the unit remains powered on to prevent freezing and cracking of pipes, thus avoiding any inconvenience in your daily life.
3. Do not install in high temperature or under the blazing sun for a long time, otherwise the service life of products will be shortened.

Note: Installation in the following locations, including areas with mineral oils like cutting oil, locations with higher salt content in the air such as coastal areas, regions with corrosive gases like sulfur in hot spring areas, factories and places with significant voltage fluctuations, vehicles, cabins, or areas with substantial vibration and shaking, areas with strong electromagnetic waves, kitchens and other spaces prone to oil and gas accumulation, locations where acid or alkali gas is present, and any other special environments, may result in machine failure.

Handling

1. This unit is heavy and requires more than two personnel for handling and installation.
2. Please handle the unit while maintaining its ex-factory status, and refrain from disassembling and assembling it on your own.
3. To prevent abrasion and deformation on the unit's surface, place a guard plate on the surface in contact with hard objects.
4. Exercise caution to avoid contact between your hands or other objects with the fan blades.
5. During handling, avoid tilting the unit beyond 15°, and strictly prohibit laying it down.

Space requirement for installation & maintenance

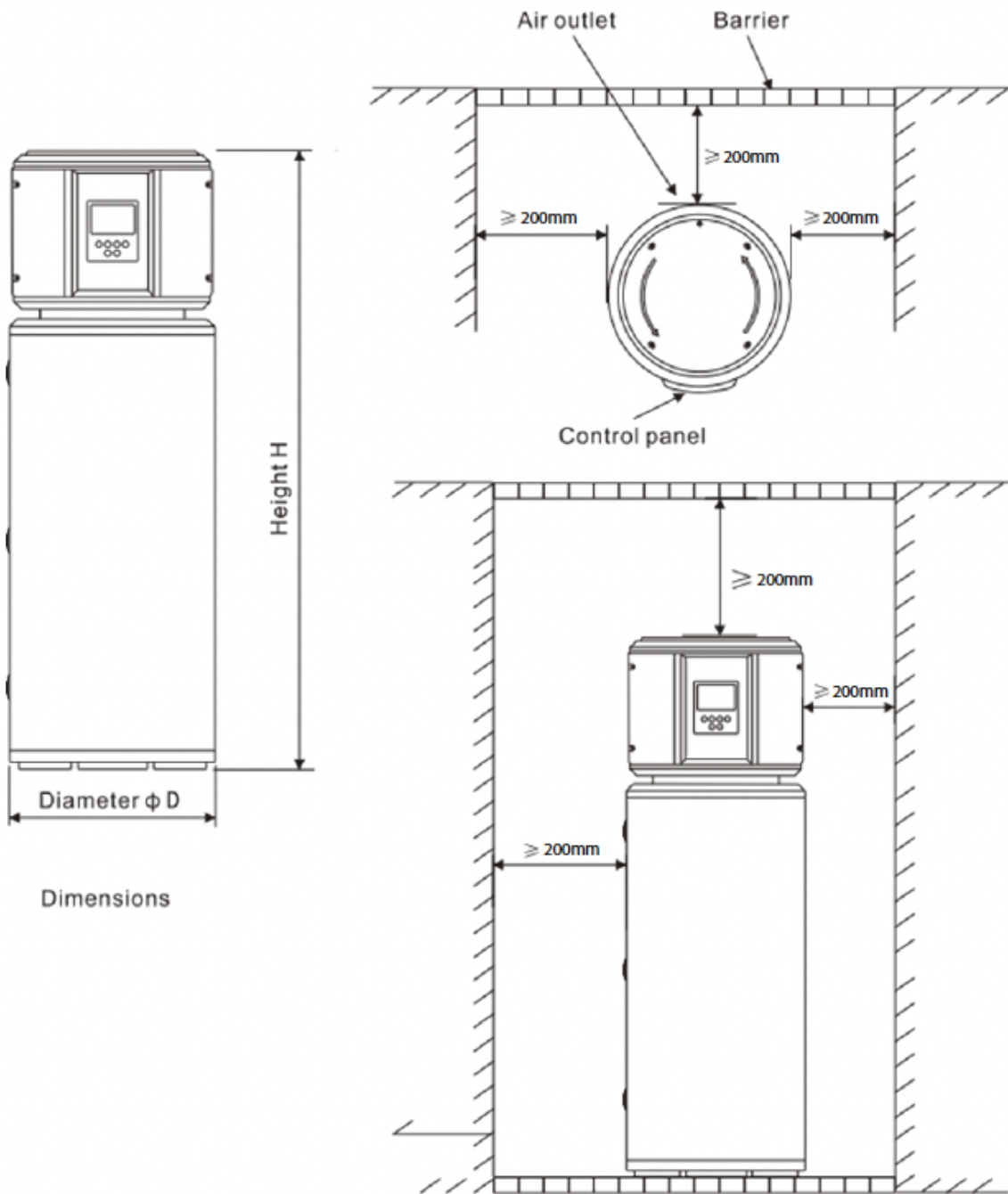

Model Parameter	WH250A-R	WH250A-C	WH250A-RE	WH250A-CE
Diameter ϕD (mm)	570	570	570	570
Height H (mm)	2140	2140	2140	2140
Height H1 (mm)	200mm	200mm	200mm	200mm

Pipeline Connection

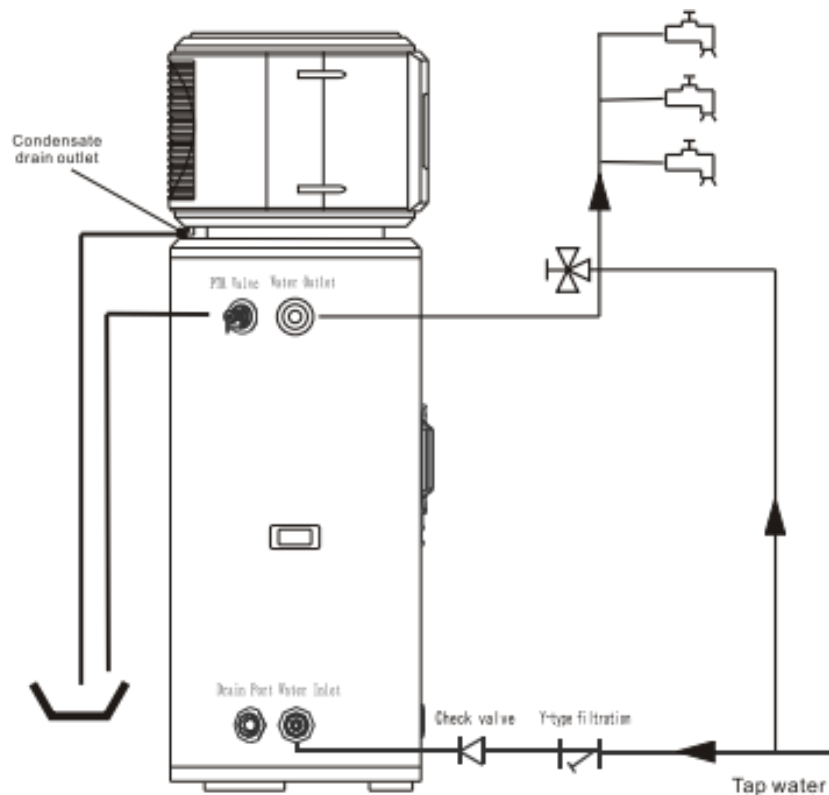

Pipeline Connection Instructions

Attention

1. Do not install the water heater with iron pipes. Water systems should exclusively utilize new pipes that adhere to drinking water standards, such as CPVC, PPR pipes, or polybutene pipes.
2. DO NOT use PVC water pipes with an unusual odor.
3. Ensure that water pipes and fittings are installed as illustrated above. In environments with temperatures below 0°C, it is imperative to insulate all water pipes during installation.

1. Installation of water inlet and outlet connecting pipe: The thread specification of water inlet and outlet of this machine is G3/4 "/internal thread). The service life of pipes and fittings used for installation and connection shall not be less than the service life of the water heater and shall have sufficient high temperature resistance to prevent damage.

2. Installation of temperature and pressure safety valve: the specification of temperature and or pressure installation valve is Rc3/4 "/inner tooth). 0.85 MPa, after installation according to the pipeline connection diagram, remove the bolts for fixing the safety valve handle and ensure that the outlet of the connected drainpipe is led the air;

Attention

1. Every six months, pull the handle of the temperature and pressure safety valve to eliminate calcium carbonate deposits and ensure the device is unobstructed. Due to the potential for very high-water temperatures at the outlet, exercise caution to prevent scalding.
2. Insulate the drainpipe to prevent freezing during winter, mitigating the risk of safety accidents.

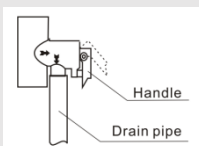

Danger

1. Do not press down the safety valve handle.
2. Never remove the safety valve
3. Never block the drain port
4. The drainpipe shall be led to an open drain outlet.



3. After all pipelines are installed, open the cold-water inlet valve and the hot water outlet valve, and start to inject water into the water tank. When the water outlet is normally discharged, it indicates that the water in the water tank has been filled. Close the outlet valve and check whether there is water leakage at the joints of all pipelines. If there is water leakage, it shall be repaired and then injected for inspection.
4. If the inlet water pressure is less than 0.15MPa, to get a larger water flow, please install a booster pump at the inlet pipe to ensure the inlet water pressure is not less than 0.15MPa. If the water supply pressure is greater than 0.65MPa, to ensure the long-term safe use of your water tank, please install the pressure reducing valve at the water inlet pipe.
5. During unit working, condensed water droplets may occur at the air outlet, and the water outlet may be accidentally blocked. In such cases, water droplets will come out from the surface of the unit. To ensure that your life will not be affected, or your belongings be damaged, it is recommended to use a water pan to collect the condensed water. Please refer to the following figure.
6. To smoothly drain condensate from unit, please install the main unit on a horizontal floor. Otherwise, please ensure the drain vent is at the lowest place. Recommended inclination angle of unit to the ground should be no more than 2°

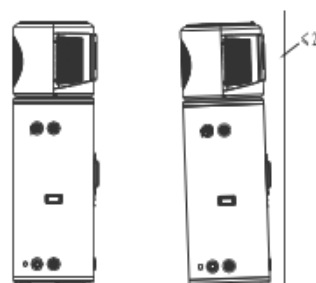
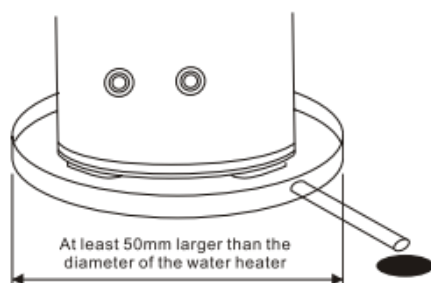

Electrical Connection

Electrical Wiring

Attention

1. It is recommended the water heater utilize a dedicated power supply, and the power supply voltage should align with the rated voltage. Please refer to your local jurisdiction for codes and regulations.
2. Ensure the power supply circuit of the water heater is adequately grounded. The grounding wire of the power supply must be securely connected to the external grounding wire, and the external grounding wire should be effective.
3. Wiring construction should be conducted by professional installation technicians in accordance with the circuit diagram.
4. Install leakage protection devices as per the specifications outlined in relevant national technical standards for electrical equipment.
5. Following the completion of all wiring tasks, conduct a thorough check before powering on the unit.

Recommended power supply specification

Model	Power supply	Wire diameter (mm ²)		Manual switch (A)		Leakage protector	Fuse (A)
		Dimensions (Continuous Length ≤30m)	Grounding wire	Capacity	Fuse		
WH250A-R WH250A-RE WH250A-C WH250A-CE	220V-240V~50Hz	≥2.5	≥2.5	30	25	30mA Below 0.1 sec	5

Electrical schematic diagram

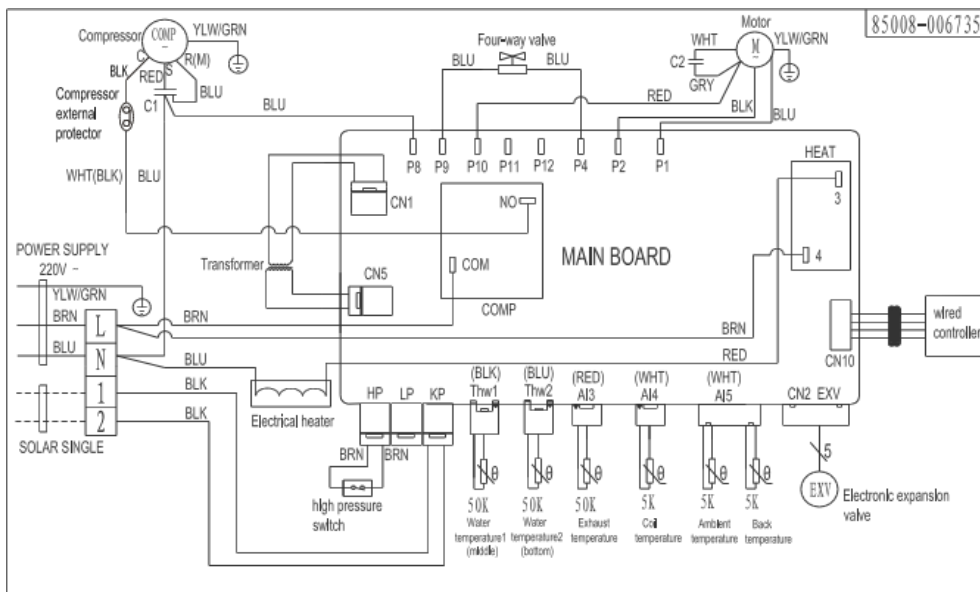

Usage Methods

When using, please follow the sequence below:

1. Water Affusion:

Before the unit is used for the first time or when the water tank is emptied and reused, ensure it is filled with water before powering on.

Refer to the water affusion method provided in the figure below.

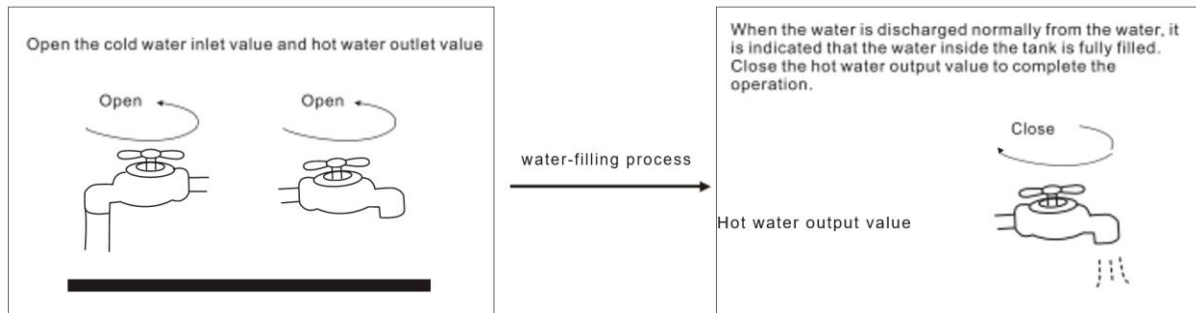

Warning

If an electric auxiliary heating unit is turned on when there is not water in the water tank, it will cause damage to the electric heating device.

2. Power On:

Turn on the power. The display screen will illuminate, indicating that the unit has been powered on. Users can switch between different modes by pressing the relevant keys on the display screen (refer to the next page for details).

Warning

If the water temperature exceeds 50°C, it poses a significant risk of severe burns and, in extreme cases, even death. Individuals at the highest risk of scalding include children, the disabled, and the elderly.

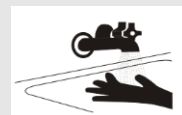

3. Water Effusion:

When cleaning or moving the machine, drain the water heater.

Follow the effusion method outlined in the figure below.

Please refer to the figures and details provided for each step to ensure proper operation.

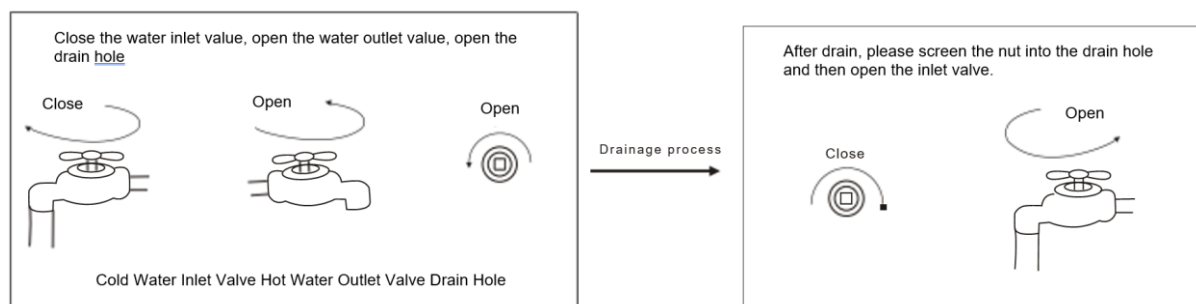











Operating Instructions



1. Display screen and operation panel



Display symbol description

No	Description	No	Description
1	 Heating mode	6	 Electric heating state
2	 Setting temperature	7	 Child lock
3	 Fault state	8	 Tank temperature
4	 Timing state	9	 WIFI status
5	 Compressor state	10	 Clock display

Description of the keys

Key Symbols	 ON/OFF	M MODE LOCK	 TIMER	 SET
Names	Turn Unit on/off	Child Lock	Set Timer	Setting

After the unit is powered on, all symbols will be displayed on the display screen, and the normal pages will be displayed after waiting for 2 seconds.



ON/OFF

- In the standby state, press the “on/off” key once to perform the startup function and display the mode before the last shutdown.
- In the start-up state, press the “on/off” key once to perform the shutdown function.
- Key combination function, press “Settings” + “On/off” at the same time and keep it for more than 3 seconds, then enter the Wifi distribution network function.



MODE LOCK

- The system will be operating in Hybrid heating mode as default.
- **HYBRID MODE:** HP is running with a 60°C setpoint and 10K dead band. If sensor temperature drops below 45degC, electric element heats up to 60d°C as one-shot boost. The element is enabled also for very low ambient temperature below -7°C.
- **ECONOMIC MODE:** HP only is running with a 60°C setpoint and 10K dead band. Element is disabled, except for very low ambient temperature below -7°C.
- **ELECTRIC MODE:** only element is running with 60°C setpoint and 15K dead band.
- Keyboard lock: When setting the child lock, press “Mode/Child lock” for 3 seconds to lock up and release the child lock.

Note: Automatic sterilisation function

Intelligently detects the temperature of the water tank, automatically enters the sterilisation function (display panel displays [DIS]) when the conditions are met, the mode will be reverted to Hybrid heating mode, and the set temperature will be set to 60°C.



TIMER

General Time Setting:

- Press and hold the "Timer" key for 3 seconds, then release to enter the time setting.
- The hours and minutes in the time display area will flash simultaneously.
- Press "Timer" again to make the hours flash, then use the "Up" or "Down" key to adjust the hours.
- Press "Timer" again to make the minutes flash, then use the "Up" or "Down" key to adjust the minutes.
- After setting, press "Timer" to save and exit.

Timed Startup:

- In the normal interface with no timing setting, press "Timer" once to enter the timed startup setting.
- The timer symbol in the time area will flash, and "ON" is displayed in the water tank temperature area.
- Default time display is 00:00, and the hour area will flash.
- Press "Setting" to switch to the minute setting, with the minute area flashing.
- Press "Setting" again to switch to timed shutdown setting.

Timed Shutdown:

- The timer symbol in the time area flashes, and "OFF" is displayed in the water tank temperature area.
- Default time display is 00:00, with the hour area flashing.
- Press "Setting" to switch to the minute setting, with the minute area flashing.
- Press "Setting" again to save the timing setting.

Cancel Timer:

- When timing is active, press "Timer" once to cancel the timing.



- During operation, press “ 【△】 → 【▽】 → 【△】 → 【▽】 → 【△】 → 【▽】 ” continuously within 5 seconds (press the key 6 times in total), and then execute the forced defrosting.



SET

Parameter Inquiry:

Press and hold the "Settings" key for 3 seconds to access the parameter inquiry page. This function is primarily designed for installation and maintenance by specialized personnel. Refer to the table below for detailed parameter information:

Code information Number	Serial number	Remarks
Tank temperature 1 (Thw 1)	01	Unit: °C
Tank temperature 2 (Thw 1)	02	Unit: °C
Ambient temperature (Ten)	03	Unit: °C
Fin temperature (Tfr)	04	Unit: °C
Compressor exhaust temperature (Tcomp)	05	Unit: °C
Return temperature (Tba)	06	Unit: °C
Current of compressor	07	Unit:A
Current opening of electronic expansion valve	08	Unit: Step
Set mode	09	00: Economic heating; 01: Hybrid heating; 02: Electric heating
Heating set temperature (Ts)	10	Unit: °C
Display water temperature	11	Unit: °C
Controller version number	12	Example: A05
Display version number	13	Example: A01
Jumper cap setting model number	14	Examples:01,02,03
Last fault code	15	Example: E1
Second last fault code	16	Example: E1
Third last fault code	17	Example: E1
Fourth last fault code	18	Example: E1

This feature allows specialized personnel to retrieve specific parameters for installation and maintenance purposes.

Trial Operation

Please confirm the following matters before trial operation

1. Whether the unit is installed correctly.
2. Whether the piping and wiring are correct.
3. Whether the drainage is smooth.
4. Whether the insulation is well done.
5. Whether the grounding wires are correctly connected.
6. Whether the power supply voltage is equal to the rated voltage of the water heater.
7. Whether there are obstacles at the air inlet and outlet.
8. Whether the air in the water pipeline is emptied, and all valves opened.
9. Whether the leakage protector can be operated effectively.
10. Whether the inlet water pressure is not less than 0.15 MPa.

Maintenance & Troubleshooting

Maintenance

The water heater has high level degree of automation, it is necessary to check the unit regularly. If the unit can be effectively maintained for a long time, the operating reliability and service life of the unit will be significantly improved.

1. Regularly clean the water filter installed outside the machine to ensure system water quality remains clean, preventing damage from a clogged filter.
2. During unit usage and maintenance, ensure all safety protection devices are set correctly as per factory settings. Avoid self-adjustments.
3. Periodically check the firmness of power supply and electrical system wiring and inspect electrical components for abnormal actions. Repair or replace as needed.
4. Regularly inspect the water system's supply solenoid valve, water tank safety valve, liquid level controller, and exhaust device to ensure proper operation. Prevent air entry to avoid reduced water circulation, impacting unit heating capacity and reliability.
5. Verify the normal operation of the water pump, waterway valves, and check for leaks in water pipelines and joints.
6. Maintain a clean, dry, and well-ventilated environment around the unit. Regularly clean the air-side heat exchanger (typically from January to February) for optimal heat transfer.
7. Check various parts of the unit regularly, inspecting pipeline joints and inflation valves for oil contamination and refrigerant leakage prevention.
8. Ensure the unit's surroundings remain clean, dry, and well-ventilated to prevent air inlet and outlet blockages.
9. If the unit remains unused for an extended period, drain the water in the pipeline, switch off the power, and set protective covers. Perform a comprehensive system inspection before the next startup.
10. In case of unit failure that cannot be resolved by the user, contact the local authorized service shop of the company for timely repairs.
11. For condenser cleaning, use a hot 15% phosphoric acid solution at 60°C. During installation, reserve a three-way interface and seal one interface for additional pipe connection during cleaning. Avoid using corrosive cleaning solutions.

12. Periodically remove the scale and discharge sewage from the water tank, typically every month based on local water quality.
13. Ensure the power plug and socket fit well, are grounded properly, and do not show signs of overheating.
14. For long periods of non-use, especially in low-temperature areas (below 0°C), discharge water from the inner tank to prevent freezing and damage.
15. To maintain long-term efficient operation, thoroughly drain and flush the water tank every six months to remove accumulated sediment.
16. The water tank is equipped with a magnesium rod to safeguard the inner container against corrosion and extend the water tank's service life. However, the magnesium rod is slowly consumed during this protective process. In certain water environments, magnesium rods can react with water. Once the magnesium rods are fully consumed, the tank liner may corrode, leading to eventual leakage. It is advisable to inspect the magnesium rod approximately once a year. If it is found to be consumed, replace it with a new magnesium rod. For specific details, kindly contact the local air conditioning customer service center or the authorized service shop.
17. For optimal efficiency, if hot water supply is sufficient, users are encouraged to lower the set temperature. This not only reduces heat loss and scale generation but also conserves electrical energy, ultimately extending the service life of the water heater.
18. In instances where the ambient temperature falls below 0°C and the water tank is installed outdoors, it is crucial to implement insulation measures for the water inlet and outlet pipes. If necessary, consider installing pipeline heating devices to prevent freezing and damage to the pipelines.

If the unit is equipped with a filter screen, it is necessary to clean the filter screen by the following instructions:

1. Unscrew the top screw of the unit and unscrew the upper cover counterclockwise;
2. Remove the upper cover and pull out the filter screen;
3. After cleaning the filter screen, dry completely and put it back.

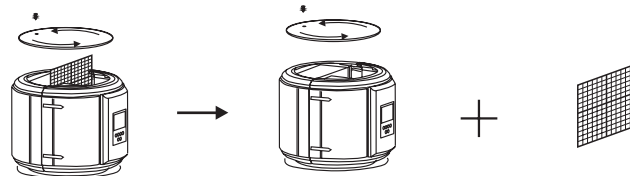

Guidelines for replacing anode protection rods.

1. Turn off the power supply of the water heater and the cold-water inlet valve.
2. Open the hot water faucet to reduce the pressure of the inner.
3. Open the drain outlet and discharge about 50L of water.
4. Remove the magnesium rod.
5. Replace with a new anode protection rod and tighten it to ensure reliable sealing, please find the Magnesium Rod replace Instructions on page 18 for detailed steps to remove the magnesium rod;
6. Open the cold-water inlet valve until water flows out of the hot water faucet, and close the hot water faucet;
7. Turn on the power supply for normal operation.

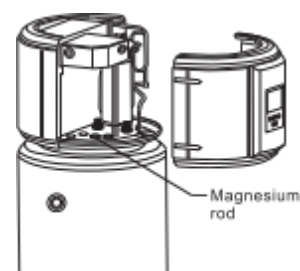

Troubleshooting

Faults	Causes	Troubleshooting
Cold water flows out. or Display screen does not light up.	<ul style="list-style-type: none"> The power plug is not plugged in. The thermostat is in a low temperature control state. Thermostat is damaged. The indicator lamp circuit board is damaged. 	<ol style="list-style-type: none"> Plug in the power plug. Adjust the temperature of the thermostat to a higher state. Notify the service technician.
No water out of the hot water outlet	<ul style="list-style-type: none"> Tap water supply is cut off; The water pressure is too low; The tap water inlet valve is not opened; 	<ol style="list-style-type: none"> Wait for tap water supply to be recovered; Reuse when the water pressure rises, Open the tap water inlet valve.
Leaking water	Poor seal at the pipe joints	Seal the pipe joints

When the machine fails and cannot run, the "Fault" icon on the display screen lights up, and the setting temperature zone displays the current fault code:

Display content	Definition of faults or protections	Display content	Definition of faults or protections
E1	Thw1 fault of hot water temperature sensor	E0	Parameter error fault
E2	High voltage fault	EA	High temperature protection of exhaust air of compressor
E3	Tfr fault of fin temperature sensor	ED	Antifreeze protection
E4	Ten fault of ambient temperature sensor	ET	The ambient temperature is not in the operating range of the heat pump
E5	Tba fault of return air temperature sensor	EE	Excessive running current of compressor
E6	Tcom fault of exhaust temperature sensor	EB	Too ow current of compressor
E7	Low pressure protection	EF	Communication fail
E8	Thw2 fault of Hot water temperature sensor		

Other display codes, not faults.

Display content	Definition	Display content	Definition
DEF	During defrosting, remind users that is in the defrosting process.	FRE	In anti-freezing, prevent the temperature of the water tank from being too low
CF	Refrigerant recovery	SP	The unit is in the non-municipal power supply state
DIS	Automatic sterilization		

Replace magnesian stick

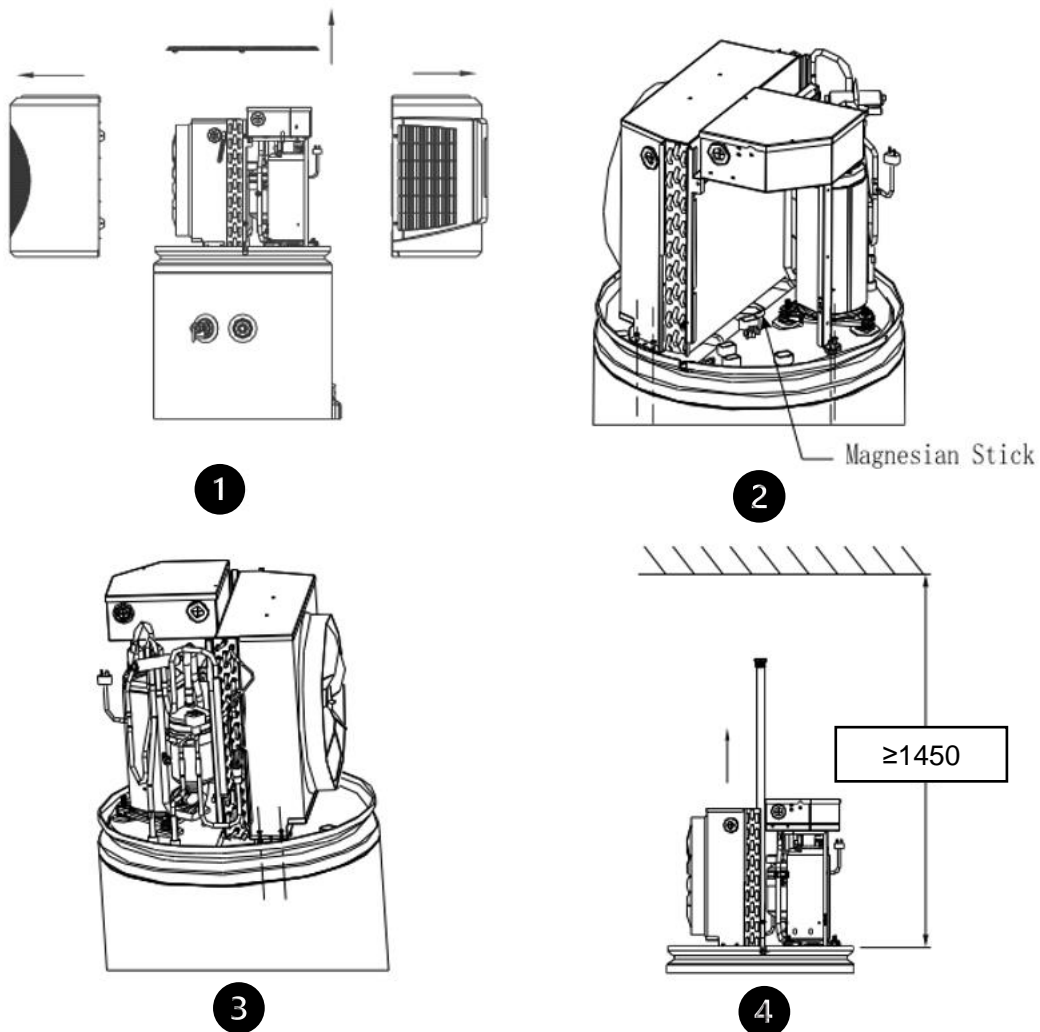

1. To access the internal components, start by removing the screws located on the top and sides of the water heater. Disconnect the cable attached to the display screen, and carefully remove the top cover, as illustrated in figure 1.

2. Locate and remove the fixing screws securing the electric control box on the water pan. Slowly move the electric control box to reveal the position of the magnesium rod. Use a specialized socket wrench for the disassembly and assembly of the magnesium rod, as depicted in figure 2.

If the magnesium rod is positioned under the evaporator, follow these steps:

- Remove the 4 screws holding the air outlet frame assembly on the water pan.
- Remove the 2 fixing screws of the electric control box on the water pan.
- Gradually move the air outlet frame assembly backward until the magnesium rod becomes visible.
- Utilize a special socket wrench to remove and replace the magnesium rod, as shown in figure 2, 3, and 4.

3. When lifting out the magnesium stick, ensure that the "H" distance is as indicated in Figure 4.

Power cord installation

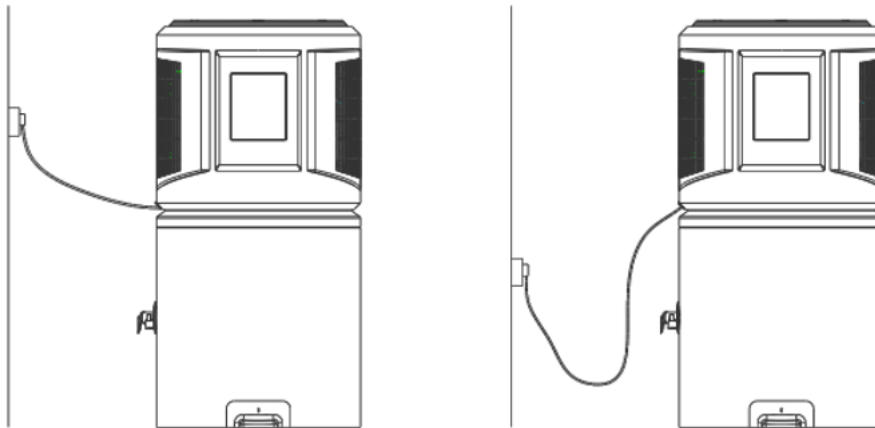

Ensure that the height of the power socket is positioned above the power line outlet to prevent water accumulation. If the socket is not elevated, reserve an appropriate length of power line to avoid ponding, as illustrated in the figure.

In the event of malfunctions with your water heater, promptly shut it down and disconnect the power supply. Contact the local technical service department for assistance.

WiFi connection

Discover the convenience of WiFi remote control with our product. Follow these steps to quickly set up and operate it with ease.

1. WiFi Network Requirements:
 - Ensure you have a WiFi wireless router with internet access.
 - The WiFi frequency band should be 2.4 GHz.
2. App Installation:
 - Scan the provided QR code or search for the [Smart Life] app in the app market.
 - Download and install the app on your mobile device.



3. App Registration:
 - Open the installed app.
 - Register an account and log in following the app prompts.

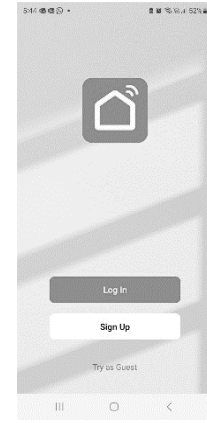

4. Device Preparation:
 - Turn on mobile WiFi and Bluetooth on
(After the connection is successful, WiFi and Bluetooth can be turned off and the control will not be affected.)

5. Enter Distribution Network Mode:
 - Power on the water heater.
 - Press and hold the [ON/OFF] + [SET] keys on the water heater display panel for 5 seconds.
Note: After entering the distribution network, you need to connect within three minutes. After more than three minutes, you need to long press the [ON/OFF] + [SET] button on the display panel for 5 seconds to reenter the distribution network.

6. Connect to WiFi:
 - Make sure your mobile device's WiFi and Bluetooth are turned on.
 - Confirm the WiFi icon on the water heater display is flashing.
 - Follow the app instructions to add the device within three minutes.

7. Automatic Device Discovery:
 - Click [Add Device] in the app.
 - The app will automatically search for devices.
 - Discovered devices will appear; click [Add].

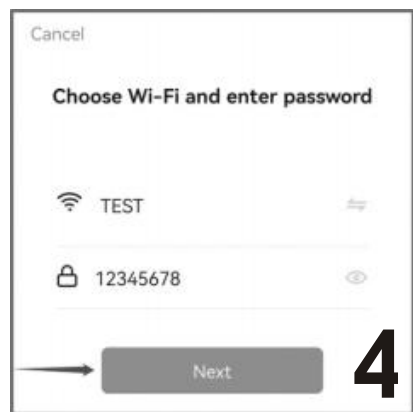
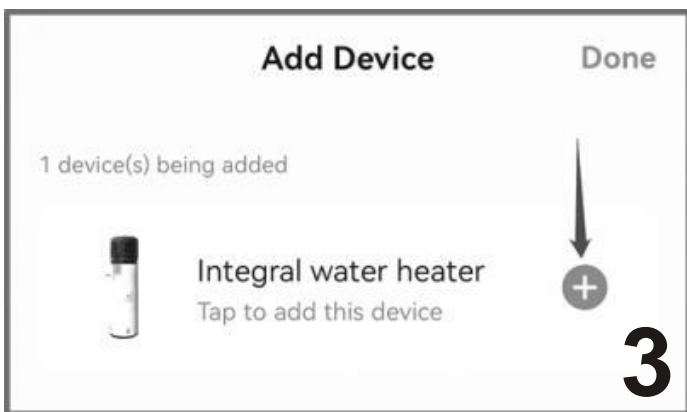

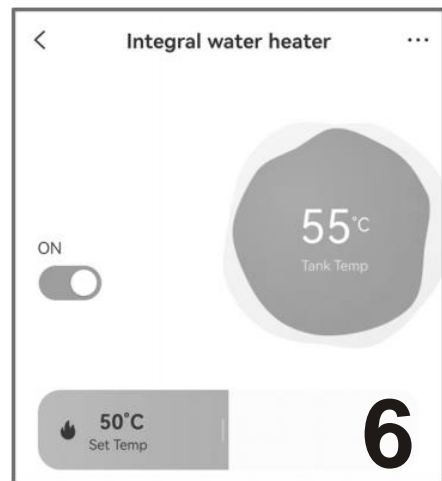
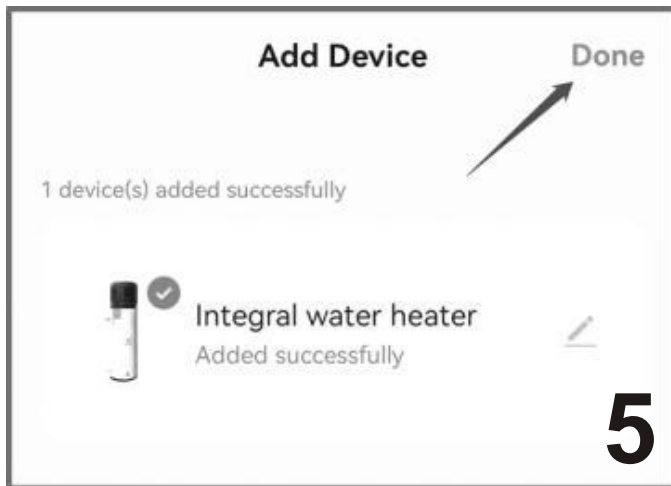

8. Connection Troubleshooting:

- If the connection fails, ensure:
 - The WiFi router is connected to the internet with a 2.4 GHz frequency.
 - The water heater is close to the WiFi router for a strong signal.
 - Your mobile phone's WiFi and Bluetooth are turned on.
 - The display panel's WiFi icon is blinking.
- After confirming the above, retry the connection following the provided sequence.

For further assistance, contact our local technical service department.



Smart Power Tech Pty. Ltd.

Service@smartpowertech.com.au

www.smartpowertech.com.au

1800 778 786

© Copyright 2023 Smart Power Tech Pty Limited ABN 28 669 711 175. As part of our commitment to continuous improvement, we may update the design of our products. Consequently, specifications are subject to change without prior notice.

Installation & operations Manual - Air-source Heat pump Heater
Doc. No.9000-01 Ver.1 2312