

SOFAR

# USER MANUAL

ESI 3-6K-S1-HA1-6 (PowerAll)



Shenzhen SOFARSOLAR Co., Ltd.



# Table of Content

Preface.....	4
1 Basic Safety Information.....	6
1.1 Requirement for Installation and Maintenance.....	6
1.2 Symbols and Signs.....	11
2 Product Introduction.....	15
2.1 Product Overview.....	15
2.1.1 Product Brief Introduction.....	15
2.2 Product Model Description.....	16
2.3 Product Capacity Description.....	18
2.4 Product Appearance.....	21
2.5 Buttons and Indicator Lights.....	24
2.6 Product label.....	26
3 Product Installation.....	27
3.1 Checking Before Installation.....	27
3.2 Installation Tools.....	27
3.3 Installation environment.....	29
3.4 Installation Space.....	31
3.5 Product Installation.....	32
4 Electrical Connection.....	36

4.1	Attentions Before Connection.....	36
4.2	Preparation of Connection Cables.....	36
4.3	Electrical Connection for Internal System.....	37
4.4	External Electrical Connection.....	41
4.5	Install the cover.....	61
4.6	Parallel system.....	61
4.7	System Electrical Topology.....	63
5	Commissioning.....	67
5.1	Checking Before System Starting.....	67
5.2	Electrify for the First Time (Important) .....	67
5.3	Menu.....	71
5.4	Time-of-use Mode.....	75
5.5	Timing Mode.....	77
5.6	Passive Mode.....	77
1)	Battery Parameter.....	79
2)	Battery Quantity.....	79
3)	Battery 1.....	79
4)	Battery Activation.....	80
5)	Set Feed-in Limit.....	80
6)	IV Curve Scan.....	80
7)	Logical Interface Control.....	81

8) Factory Reset.....	81
9) Parallel Setting.....	81
10) Bluetooth Reset.....	82
11) CT Calibration.....	82
12) Set ElectricityMeter.....	82
13) NeutralPointGrounding.....	83
6 Trouble shooting and maintenance.....	89
6.1 Troubleshooting.....	89
6.2 Daily Maintenance.....	107
6.3 Store and charge the battery module.....	107
7 Datasheet.....	110
8 Manufacturer's Warranty and Liability Terms.....	115

# Preface

## Notice

The products, services or features you purchased shall be subject to the company's commercial contracts and terms. All or part of the products and services described in this document may not within the scope of your purchase. Unless additional terms and conditions in your contract, the company does not make any statement or guarantee on the contents of this document. In addition, the term "Product" as described in this document refers broadly to "ESI Series products".

## Save this Instruction

This manual must be considered as an integral part of the equipment. Customer can print the electronic version to hard copy and keeping properly for future reference. Anyone who operates the device at any time must operate in accordance with the requirements of this manual.

## Copyright Declaration

The copyright of this manual belongs to SHENZHEN SOFARSOLAR Co., Ltd. Any corporation or individual should not plagiarize, partially cope or fully copy (including software, etc.), not allow to duplication and publishment in any form and any way. All rights reserved, SOFAR reserves the right of final interpretation. This manual subject to modify according to user's or customer's feedback. Please check our website at <http://www.sofarsolar.com> for latest version.

## Document Updates

V4.0 2023-11-01

- Initial version

- **Outline**

Please read the product manual carefully before installation, operation or maintenance. This manual contains important safety instructions and installation instructions that must be followed during installation and maintenance of the equipment.

- **Scope of Validity**





This product manual describes the installation, electrical connections, commissioning, maintenance and troubleshooting of ESI Series products.

- **Target Group**

This manual is for qualified electricians. The tasks described in this manual only can be performed by qualified electricians.

- **Symbols Used**

The following types of safety instruction and general information appear in this document as described below:

	<p>“Danger” indicates a hazardous situation which, if not avoided, will result in death or serious injury.</p>
<p><b>Danger</b></p>	
	<p>“Warning” indicates a hazardous situation which, if not avoided, could result in death or serious injury.</p>
<p><b>Warning</b></p>	
	<p>“Caution” indicates a hazardous situation which, if not avoided, could result in minor or moderate injury.</p>
<p><b>Caution</b></p>	
	<p>“Attention” indicates there are potential risks, if fail to prevent, may lead to equipment cannot normally or property damage.</p>
<p><b>Attention</b></p>	
	<p>“Note” provides additional information and tips that are valuable for the optimal operation of the product, will help you to solve a problem or save your time.</p>
<p><b>Note</b></p>	

# 1 Basic Safety Information

## Outlines of this Chapter

Please read the instruction carefully. Faulty operation may cause serious injury or death.

	<p>If you have any question or problem when you read the following information, please contact SHENZHEN SOFARSOLAR CO., Ltd.</p>
<p>Note</p>	

## 1.1 Requirement for Installation and Maintenance

### Common Requirements

The product must be installed in full compliance with national and local power grid standards and regulations.

Before installing and adjusting the produce, please read all of instructions, cautions and warnings in this manual.

Before connecting the product to the electrical utility grid, contact the local utility company for allowance. Also, this connection must be made only by qualified electrician.

When any maintenance or repair is required, please contact the nearest authorized maintenance center. If you don't know which service center is closest to you, please contact your local distributor. Don't repair the product by yourself, which may lead serious injury or damage.

Before installing and maintaining the device, using the DC switch to cut off the high voltage direct current of the photovoltaic array. Otherwise, the high voltage may cause serious injury.

- ✧ The product should be placed in a well-ventilated place. Do not place the product in a sealed or air-tight position or cabinet, otherwise it will affect the operation performance and system life of the energy storage system.
- ✧ Avoid direct sunlight. Do not place this product near stoves and fire sources. Otherwise, the lithium battery in the product system will leak or even explode.
- ✧ The maintenance personnel of this product must understand the knowledge and skills related to inverter and battery maintenance.
- ✧ ESI Series products are transformerless inverter which requires the positive pole and negative pole of the PV array are NOT grounded. Otherwise, it will cause inverter failure. In the PV system, all non-current-carrying metal parts (such as mounting frame, combiner box enclosure, etc.) should be connected to earthed.
- ✧ Reminder: Do not disassemble and destroy the battery. The toxic electrolyte in the battery can damage your skin and eyes.
- ✧ Caution: Comply with the following requirements during the installation and maintenance of the product:
  - ✧ A) Remove watches, rings and other metal objects from your body.
  - ✧ B) Use tools with insulated handles.
  - ✧ C) Wear rubber gloves and shoes.
  - ✧ D) Do not place tools or metal objects on the battery.

- ◇ E) Close the inverter before connecting/disconnecting the battery and the energy storage inverter.
- ◇ F) Battery +/- pole shall be isolated from ground.
- ◇ Installation and maintenance personnel requirements

When the product is in the running state, some parts may be electrified and hot. Improper use, improper installation or operation may result in serious injury to person or property. Transport, loading, unloading, installation, start-up and maintenance operations must be performed by a qualified electrical engineer (all accident precautions in force in the user's country must be followed!) SOFAR will not be responsible for any personal injury or property injury caused by improper use.

- ◇ Installation location requirement

Please install the product according to the following section. Place inverter in an appropriate bearing capacity objects (such as solid brick wall, or strength equivalent mounting surface, etc.) and make sure inverter vertical placed. A proper installation location must have enough space for fire engine access in order for maintenance if faulty occur. Ensure the inverter is installed in a wall ventilated environment and have enough air cooling cycle. Air humidity should less than 90%.

### **Transportation Requirement**

Inverter is in the good electrical and physical condition when it ship out from factory. During transport, inverter must be placed in its original package or other proper package. Transportation company should responsible for any damage during transport period.

If you find any packing problems that may cause the damage of inverter or any visible damage, please notice the responsible transportation company immediately. You can ask your installer

or SOFAR for help is necessary.

This product contains battery module through UN38.3, belongs to the ninth category of dangerous goods. Therefore, loading and unloading must comply with local laws and regulations and industry standards during transportation. Rough loading and unloading may cause short circuit or damage to batteries in containers, which may result in battery leakage, breakage, explosion, or fire.

### Transportation Requirement



- ✧ Shipping complies with the IMDG CODE and the International Maritime Dangerous Goods CODE.
- ✧ For land transportation, comply with ADR or JT T617 shipping requirements.
- ✧ Meet the regulatory requirements of the transport regulatory authorities of the country of origin, route and destination.

Comply with international regulations for the transport of dangerous goods and the supervision requirements of the corresponding national transport regulatory authorities.



### Electrical Connection

Please comply with all the current electrical regulations about accident prevention in dealing with the current inverter.



	<p>Before the electrical connection, use opaque material to cover the PV modules or disconnect PV string DC switch. PV arrays will produce dangerous voltage if it is exposure under sun. When installing a battery, check the positive and negative terminals of the battery and turn off the</p>
<b>Danger</b>	

	battery.
	All operation must accomplish by certified electrical engineer <ul style="list-style-type: none"> <li>● Must be trained;</li> <li>● Completely read the manual operation and understand all information.</li> </ul>
<b>Warning</b>	
	Must get permission by local utility company before connecting to grid and the connection must be done by certified electrical engineers.
<b>Attention</b>	

### Operation Cautions

	Touching the utility grid or the terminal conductors can lead to lethal electric shock or fire!
<b>Danger</b>	Do not touch non-insulated cable ends, DC conductors and any live components. Attention to any electrical relevant instruction and document.
	Enclosure or internal components may get hot during operation. Please wear insulated gloves.
<b>Attention</b>	

### Maintenance and Repair Cautions

	Before any repair work, turn OFF the AC circuit breaker between the product and electrical grid first, then turn OFF the DC switch. After turning OFF the AC circuit breaker and DC switch wait for at least 5 minutes before carry any maintenance or repair work.
<b>Danger</b>	
	Product should not work again until removing all faults. If any repair work is required, please contact local authorized service center. Should not open the product cover without

<b>Attention</b>	authorized permit, SOFARSOALR does not take any responsibility for that.
------------------	--

**EMC/Noise Level**



Electromagnetic compatibility (EMC) refers to that on electrical equipment functions in a given electromagnetic environment without any trouble or error, and impose no unacceptable effect upon the environment. Therefore, EMC represents the quality characters of an electrical equipment.

- The inherent noise-immune character: immunity to internal electrical noise
- External noise immunity: immunity to electromagnetic noise of external system

Noise emission level: influence of electromagnetic emission upon environment

	Electromagnetic radiation from the product may be harmful to health! Please do not continue to stay away from the product in less than 20cm when it is working
<b>Danger</b>	





**1.2 Symbols and Signs**







	High voltage of inverter may be harmful to health! Only certified engineer can operate the product; Juveniles, Disable, should not use this product; Keep this product out of the reach of children;
<b>Danger</b>	
	Caution of burn injuries due to hot enclosure! Only touch the screen and pressing key of the product while it is working
<b>Caution</b>	
	PV array should be grounded in accordance to the requirements of the local electrical grid company

<b>Attention</b>	
	Ensure the maximum DC voltage input is less than the product's maximum DC voltage (including in low temperature condition). Any damage cause by over-voltage, SOFAR will not take the responsibility including warranty
<b>Warning</b>	

The product has some safety symbols on it. Please read and fully understand the content of the symbols before installation.





### Sings on the inverter module

Symbols	Name	Explanation
	This is a residual voltage in the inverter module!	After disconnect with the DC side, there is a residual voltage in the inverter module, operator should wait for 5 minutes to ensure the capacitor is completely discharged.
	Caution of high voltage and electric shock	The inverter module operates at high voltages. Prior to performing any work on the product, disconnect the product from voltage sources. All work on the product must be carried out by qualified persons only.
	Caution of hot surface	The inverter module can get hot during operation. Avoid contact during operation. Prior to performing any work on the product, allow the product to cool down sufficiently.
	Comply with European standard (CE) certification	The product complies with the CE Certification

	Grounding Terminal	Connect the inverter module to the ground bar for grounding protection
	Observe the documentation	Read all documentation supplied with the product before install
	Positive pole and negative pole	Positive pole and negative pole of the input voltage (DC)
	Temperature	Indicated the temperature allowance range
	This side up	Inverter must always be transported, handled and stored in such a way that the arrows always point upwards.
	RCM (Regulatory Compliance Mark)	The product complies with the requirements of the applicable Australian standards

### Sings on the battery module

Symbols	Name	Explanation
	This is a residual voltage in the battery module!	After the battery is powered on, there is a high voltage. After the battery is powered off, the internal capacitor is still charged, operator should wait for 5 minutes to ensure the capacitor is completely discharged.

	<p>Caution of high voltage and electric shock</p>	<p>The inverter module operates at high voltages. Prior to performing any work on the product, disconnect the product from voltage sources. All work on the product must be carried out by qualified persons only.</p>
	<p>Caution of hot surface</p>	<p>The inverter module can get hot during operation. Avoid contact during operation.</p>
	<p>Grounding Terminal</p>	<p>Connect the battery module to the ground bar for grounding protection</p>
	<p>Observe the documentation</p>	<p>Read all documentation supplied with the product before install.</p>

## 2 Product Introduction

### 2.1 Product Overview

#### 2.1.1 Product Brief Introduction

ESI series single-phase household energy storage system consists of inverter module and lithium battery module. It adopts modular design and can be stacked with building blocks. The battery capacity ranges from 5kWh to 30kWh. The system can manage the energy of photovoltaic, battery, utility grid and load according to the actual application, and realize the optimal distribution of system energy. Multiple working modes are available to meet diverse needs.

The main features are as follows:

- Stack integrated design, convenient installation, simple maintenance;
- Built-in battery pack equalization management unit to improve battery available capacity;
- Photovoltaic maximum input current 16A, applicable to large current and double-sided module;
- Battery side complete electrical isolation, safer system;
- UPS function to ensure the stable operation of critical load;
- Supports a mixture of new and old batteries;
- Supports battery switch off with a button.

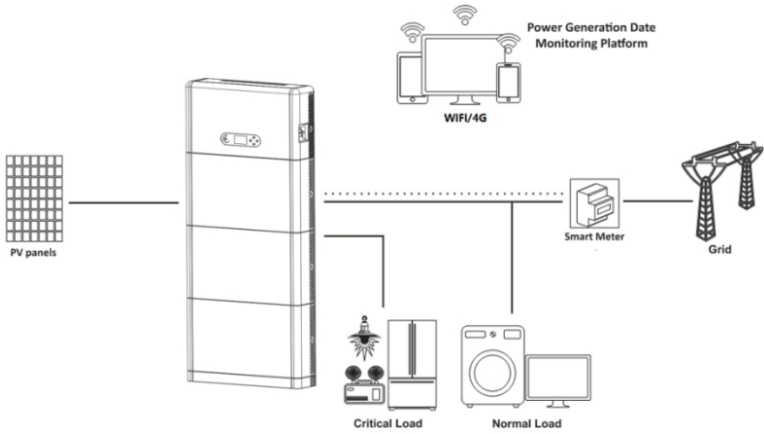

Figure 2.1.1-1 ESI series application principle diagram

## 2.2 Product Model Description

ESI series inverter model:

**ESI 5K-S1**  
 \_\_\_\_\_  
 ①            ②            ③

Figure 2.2-1 Inverter Model Identifiers

Table 2.2-1 Inverter Model demonstration

Identifiers	Meaning	Specification
①	Product Model	Stacked optical storage all in one machine
②	Power Grade	5K, the power grade of inverter is 5kw

		Power grade list: 3kw/3.68kw/4kw/4.6kw/5kw/6kw
③	Inverter Model	Single-phase hybrid energy storage inverter

ESI series battery module model:

**BTS 5K**

①

②

Figure 2.2-2 Battery module model identifiers

Table 2.2-2 Battery module model demonstration

Identifiers	Meaning	Specification
①	Product series name	SOFAR BTS series battery module name
②	Battery module power grade	5K: Battery module power is 5kWh

ESI series system model:

**ESI 6K-S1-HA3**

①

②

③

④

Figure 2.2-3 Model identifiers

Table 2.2-3 Model demonstration

Identifiers	Meaning	Specification
①	Product category	Stacked optical storage all in one machine
②	Power grade	6K, the power grade of inverter is 6kw
③	Inverter model	Single-phase hybrid energy storage inverter
④	Battery module quantity	HA3 means 3 battery modules

### 2.3 Product Capacity Description

The ESI series residential energy storage system supports power and capacity expansion and supports up to six inverter modules in parallel. One inverter module supports up to six batteries expansion modules.

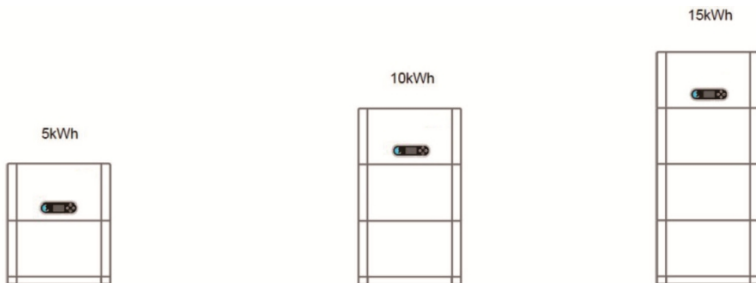

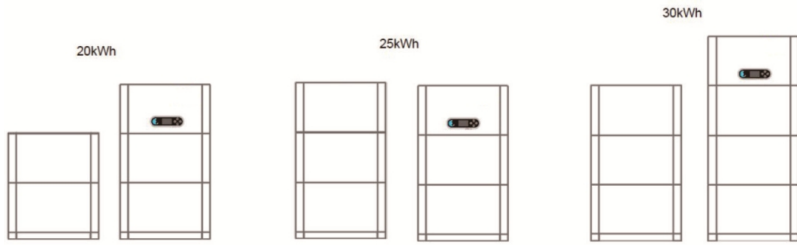





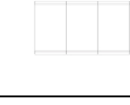
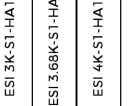
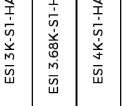
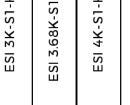
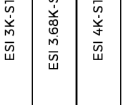
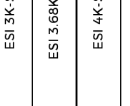
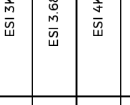
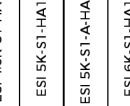
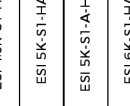
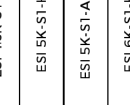
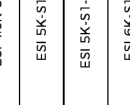
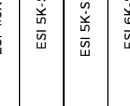
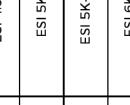



















Figure 2.3-1 Storage Capacity Description

Table 2.3-1 ESI series product model list

					
ESI 3K-S1-HA1	ESI 3K-S1-HA2	ESI 3K-S1-HA3	ESI 3K-S1-HA4	ESI 3K-S1-HA5	ESI 3K-S1-HA6
					
ESI 3.68K-S1-HA1	ESI 3.68K-S1-HA2	ESI 3.68K-S1-HA3	ESI 3.68K-S1-HA4	ESI 3.68K-S1-HA5	ESI 3.68K-S1-HA6
					
ESI 4K-S1-HA1	ESI 4K-S1-HA2	ESI 4K-S1-HA3	ESI 4K-S1-HA4	ESI 4K-S1-HA5	ESI 4K-S1-HA6
					
ESI 4.6K-S1-HA1	ESI 4.6K-S1-HA2	ESI 4.6K-S1-HA3	ESI 4.6K-S1-HA4	ESI 4.6K-S1-HA5	ESI 4.6K-S1-HA6
					
ESI 5K-S1-HA1	ESI 5K-S1-HA2	ESI 5K-S1-HA3	ESI 5K-S1-HA4	ESI 5K-S1-HA5	ESI 5K-S1-HA6
					
ESI 5K-S1-A-HA1	ESI 5K-S1-A-HA2	ESI 5K-S1-A-HA3	ESI 5K-S1-A-HA4	ESI 5K-S1-A-HA5	ESI 5K-S1-A-HA6
ESI 6K-S1-HA1	ESI 6K-S1-HA2	ESI 6K-S1-HA3	ESI 6K-S1-HA4	ESI 6K-S1-HA5	ESI 6K-S1-HA6

## 2.4 Product Appearance

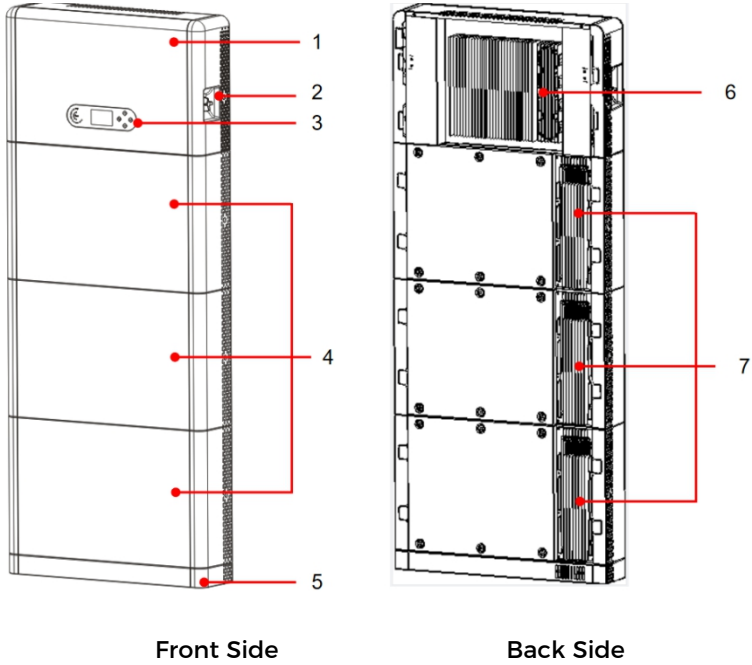

Figure 2.4-1 Product front side and back side

1	Inverter	2	DC Switch
3	LCD display screen	4	Battery Module
5	Pedestal	6	Inverter Radiator
7	Battery Module Radiator		

### 2.4.1 Inverter Port

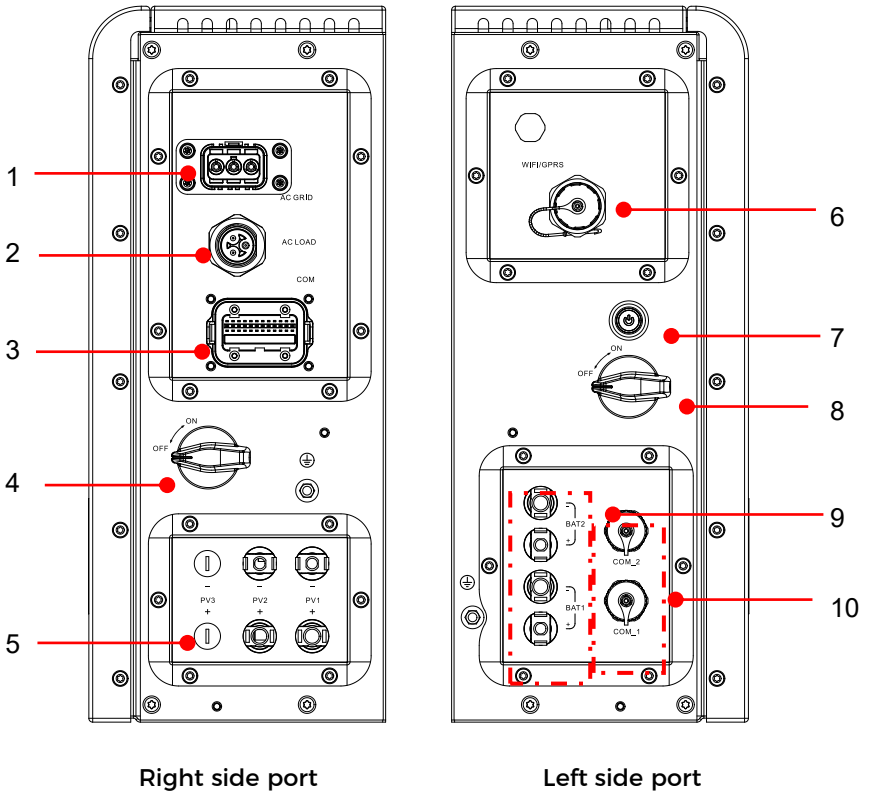
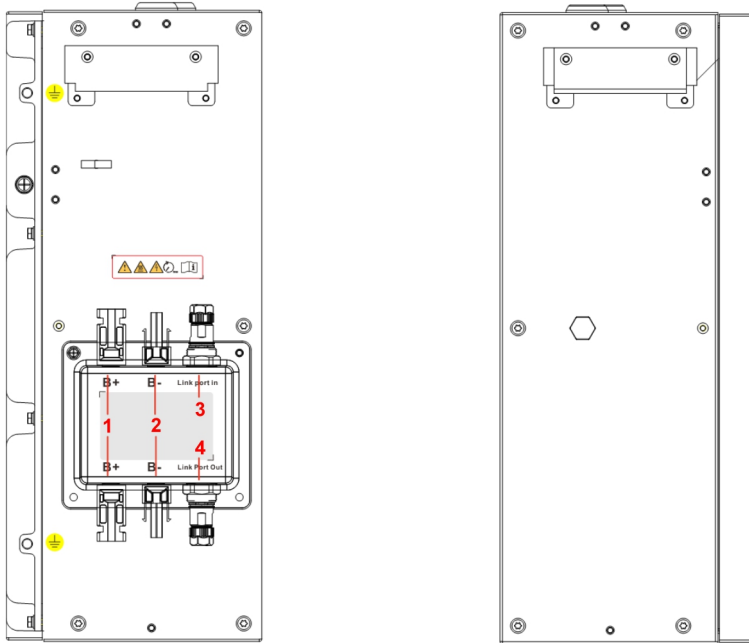

Figure 2.4.1-1 Inverter port diagram

1	Grid connection port	6	WIFI/4G port
2	Load connection port	7	Battery black start switch
3	Inverter signal port	8	Battery input switch
4	DC Switch	9	Battery connection port

5	PV input port	10	Battery signal port
---	---------------	----	---------------------

### 2.4.2 Battery Module Port



Battery Left Side

Battery Right Side

Figure 2.4.2-1 Battery module port diagram

1	Battery output terminal +	3	Link Port In
2	Battery input terminal -	4	Link Port Out

## 2.5 Buttons and Indicator Lights

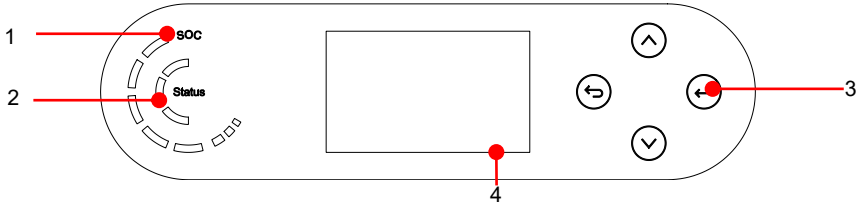

Figure 2.5-1 Buttons and indicator lights

1	System power indicator	3	Buttons
2	System status indicator	4	LCD screen





### 2.5.1 Buttons

- ✧ Press “back” to the previous screen or enter the main interface.
- ✧ Press “up” to the upper menu option or value plus 1.
- ✧ Press “down” to the lower menu option or value minus 1.
- ✧ Press “ok” to select the current menu option or switch to the next digit.

### 2.5.2 System status indicator

System Status	Indicator		
	Blue light	Green light	Red light
On-grid	ON		
Standby(On-grid)	Flashing		
Off-grid		ON	
Alarm			ON

### 2.5.3 Battery capacity indicator

Icon	Battery capacity	Capacity explanation
	80%-100%	The battery capacity is full
	60%-80%	
	40%-60%	
	20%-40%	
	0-20%	The battery capacity is insufficient, and the battery generates a low voltage alarm.



## 3 Product Installation



### 3.1 Checking Before Installation





#### Checking Outer Packing Materials

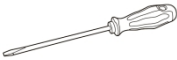

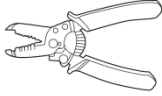

Before opening the battery and inverter package, check whether the outer package is damaged, such as holes and cracks, and check the inverter and battery model. If any damage is found or the inverter and battery model does not match your requirements, please do not open the product package and contact your distributor as soon as possible.

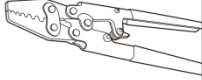
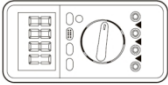
### 3.2 Installation Tools

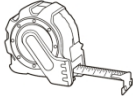
Before installation, prepare the following tools:

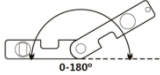
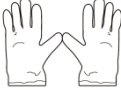
NO	Tool	Model	Function
1		Hammer drill Recommend Drill @ $\Phi 8\text{mm}$	Used to drill holes on the wall.
2		Screwdriver	Remove and install screws and wires
3		Cross screwdriver	Remove and install screws and wires

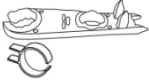
4		Wire stripper	Used to peel cable
5		M6 socket head wrench	Secure the backplane and inverter
6		Crimping Tool	Use to crimp cable on grid side, load side and CT extensive cable
7		Multimeter	Check whether the cable connection is correct, the positive and negative terminals of the battery are correct, and the grounding is reliable
8		Marker	Mark signs
9		Measuring tape	Measure distance

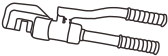
10		Level	Ensure the rear panel is properly installed
11		ESD gloves	Installer wear when installing product
12		Safety goggle	Installer wear when drill holes
13		Mask	Installer wear when drill holes
14		Removal Tool	Remove the output terminal of the battery module
15		sleeve	Install Fixed support rack
16		Crimping tools	Used to crimp OT connector

### 3.3 Installation environment

- ✧ Choose a dry, clean, neat and convenient location for installation.
- ✧ Machine ambient temperature: -10°C~50°C;

- ✧ Relative humidity: 5-95% (non-condensing);
- ✧ The product should be placed in a well-ventilated place;
- ✧ There are no inflammable and explosive objects near the installation position of the product;
- ✧ The product system inverter AC over-voltage level is three;
- ✧ The highest altitude of the installation environment is 4000m.

The installation position of the product should be chosen to avoid direct sunlight, snow position

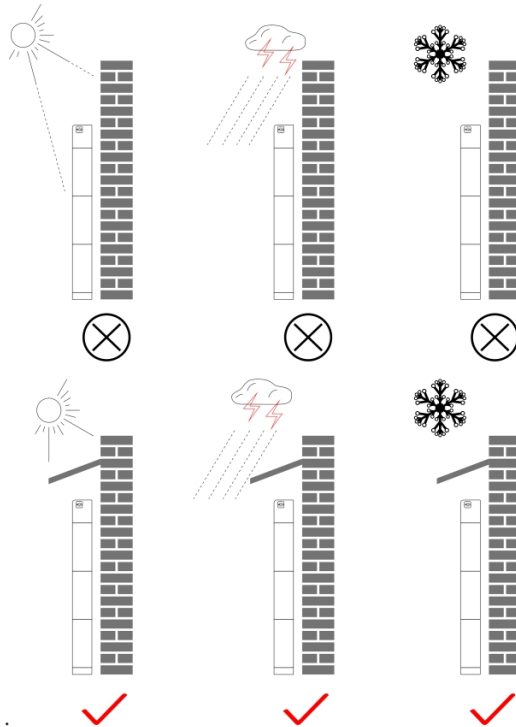

Figure 3.3-1 Installation Environment Diagram

### 3.4 Installation Space

To ensure sufficient space for installation and heat dissipation, reserve sufficient space around the ESI series household energy storage system. The requirements are as follows:

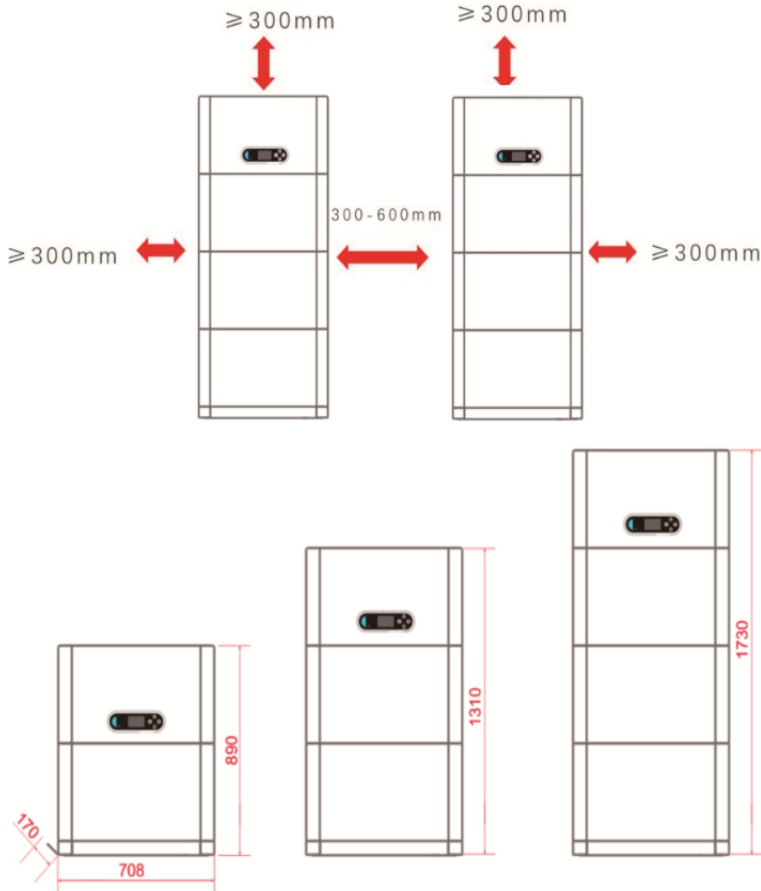

Figure 3.4-1 Installation space diagram

### 3.5 Product Installation

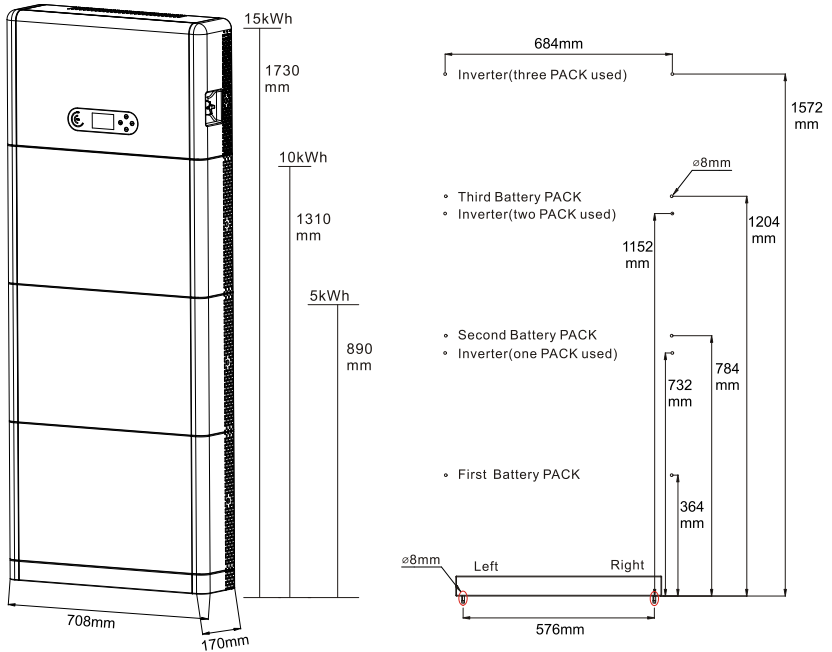

Figure 3.5-1 ESI series installation dimensions diagram

#### Pedestal installation

Procedure:

1) Place the pedestal against a wall and keep it 10 to 25mm away from the wall. Adjust the hole positions using a level, and mark the hole positions using a marker.

2) To install the pedestal, remove the pedestal, drill holes using a hammer drill ( $\phi$  8mm, depth range 60-65 mm), and tighten expansion screws to ensure that the base is securely

installed.

3) Use a marker to mark holes for securing the battery modules and inverters based on the dimensions shown in Figure 3.7-1.

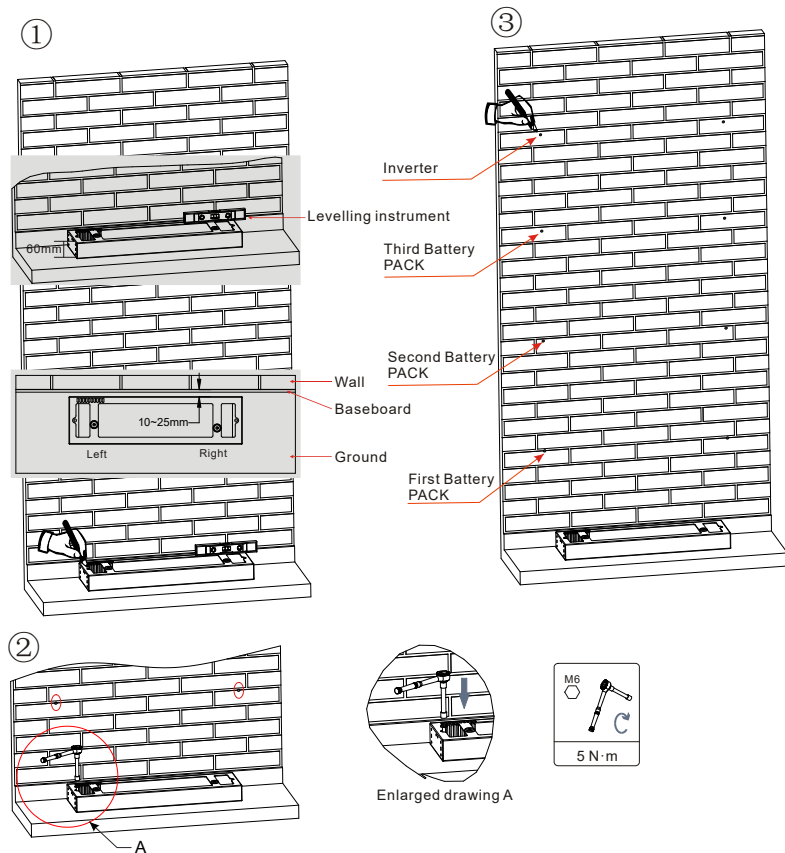

If holes cannot be drilled on the ground, the battery expansion modules must be secured on the wall

Figure 3.5-2 Pedestal installation

Fixed installation between modules:

**Procedure:**

- 1) Align the first battery module on the floor pedestal.
- 2) Install connectors on both sides and tighten the six screws using a cross screwdriver.
- 3) Install the remaining battery modules and inverters from bottom to top. (Before installing the next module, ensure that the screws on the side connectors of the previous module are firmly installed.)

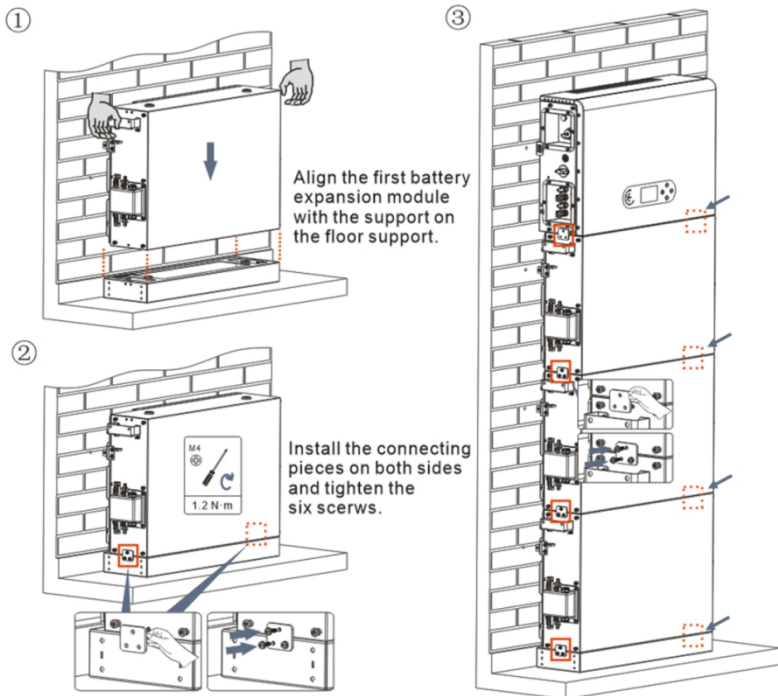

Figure 3.5-3 Battery module and inverter installation diagram

**Support rack installation:**

Procedure:

1) Drill holes with a hammer drill ( $\phi$  8mm, depth range 60-65 mm). Reposition and drill the holes, if the original one has a large deviation.

2) Install the support rack B on the wall, and fastening expansion bolt.

3) Adjust the support rack A, make sure the holes are matched between rack A and rack B.

4) Connect and fix the rack A and rack B with M6\*16 screws.

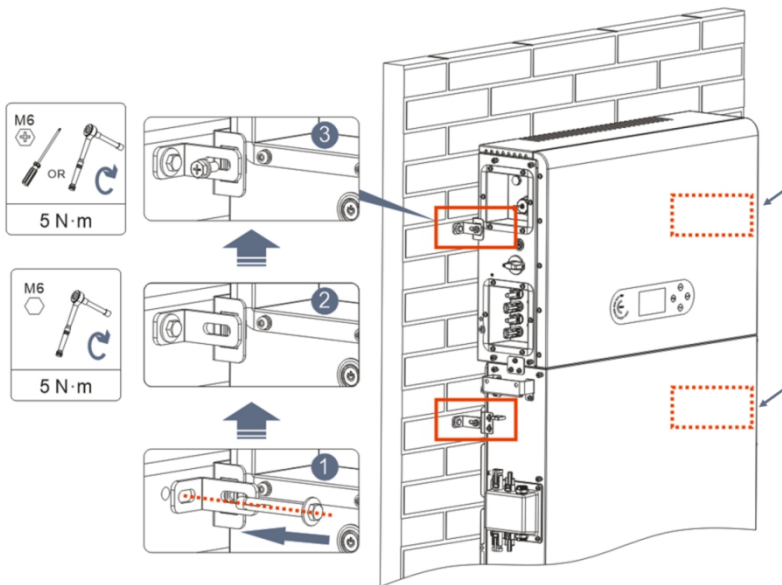



Figure 3.5-4 Schematic diagram of wall fixing installation

## 4 Electrical Connection

### 4.1 Attentions Before Connection

	<p>The voltage in the power conversion circuit of this product is very high. Fatal danger of electric shock or severe burns. All electrical connections of photovoltaic modules, inverters and battery systems must be carried out by qualified personnel. Wear rubber gloves and protective clothing (protective glasses and boots) when operating high voltage/current systems such as inverters and battery systems.</p>
<p><b>Attention</b></p>	<p>This product is mainly applied to photovoltaic energy storage systems for household use. If not used according to the instructions, the protection provided by the equipment may be damaged.</p>

### 4.2 Preparation of Connection Cables

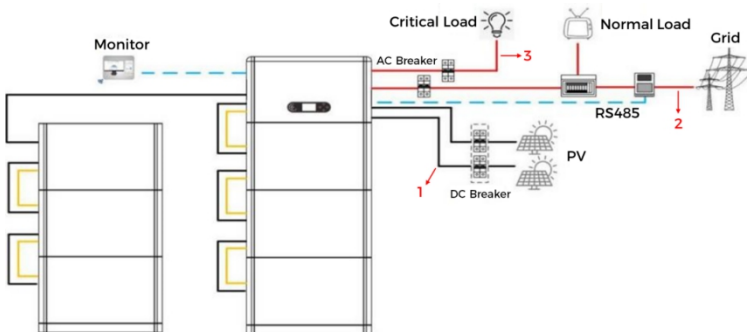

Figure 4.2-1 System connection diagram

Table 4.2-1 Cables prepared by customers

No	Cable	Recommended specifications
1	PV connection cable	UL10269 12AWG
2	AC Grid connection cable	UL10269 8AWG
3	EPS connection cable	UL10269 10AWG
4	Grounding cable	UL10269 8AWG

### 4.3 Electrical Connection for Internal System

#### 4.3.1 Internal protection grounding cable connection

Connect the grounding cables of the battery module and inverter as shown in Figure 4.3.1-1.

	<p><b>Be sure to ground for safety.</b></p> <ul style="list-style-type: none"> <li>● The protective grounding of the chassis shell cannot replace the PGND cable of the LOAD Port. Ensure that the two PGND cables are reliably connected.</li> <li>● When multiple inverters are deployed, ensure that the protection ground points of all inverters are equipotential connected.</li> </ul>
<p><b>Attention</b></p>	

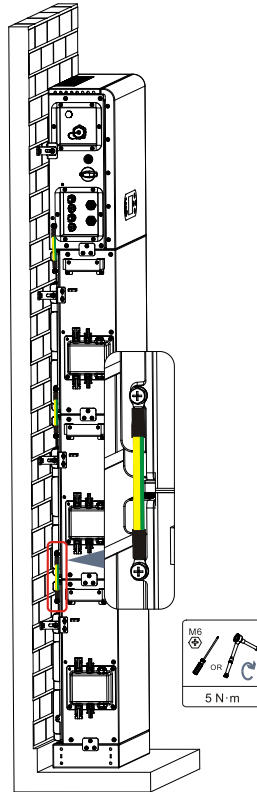

Figure 4.3.1-1 Internal grounding cable connection

#### 4.3.2 Power cables connection

As shown in Figure 4.3.2-1, connect the power ports (BAT+, BAT-) of the inverter to the cascading positive and negative power cables (B+,B-) of the battery module. Connect the remaining battery modules from top to bottom, and secure the cables with cable ties. Ensure that the cables are securely connected.

#### Precautions during installation:

- If the system capacity is greater than 15kWh, the batteries are connected to the inverter's battery input interface in two independent groups.

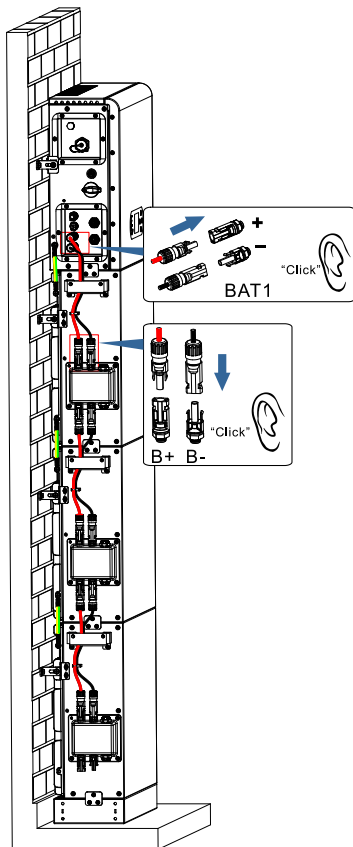

Figure 4.3.2-1 Connection of battery internal DC terminal

### 4.3.3 Internal communication cable connection

Connect the communication terminals of the inverter and battery module from top to bottom according to 4.3.3-1 in the

following figure, and secure them with cable ties. For the communication cable, tighten the large nut and then the small nut. In addition, install a matching terminal resistance on the communication interface of the last battery module in the system.

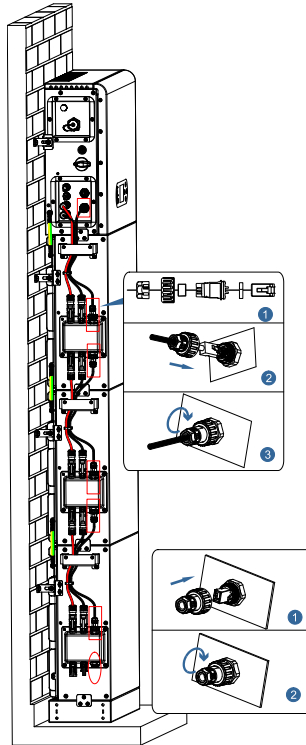

Figure 4.3.3-1 Internal signal cable connection

#### 4.3.4 Data collector connection

Connect the standard WIFI/4G collector in the inverter package according to 4.3.4-1 in the following figure.

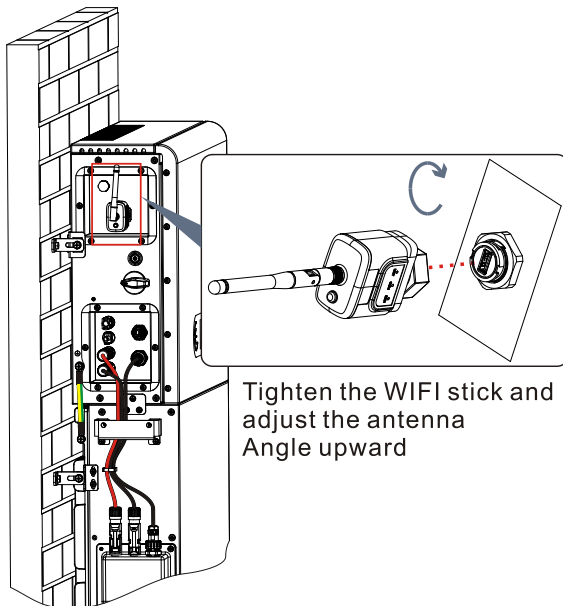

Figure 4.3.4-1 WIFI/4G connection

## 4.4 External Electrical Connection

### 4.4.1 External ground Connection of the PGND cable

#### Procedure 1 Crimp OT terminals

#### Precautions:

- When stripping the cable, do not scratch the core of the cable.
- The conductor crimping plate of an OT terminal is pressed to form a cavity that completely covers the conductor core and tightly binds the OT terminal.

- The crimping line can be covered with heat shrink tubing or insulation tape.

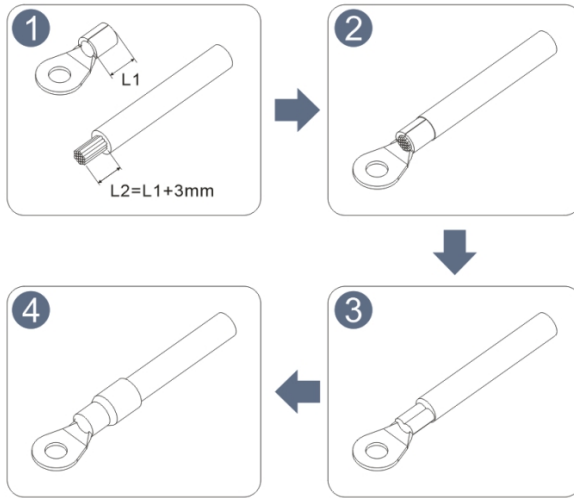

Figure 4.4.1-1 Diagram of Crimping OT terminals

**Procedure 2** The OT terminal is crimped properly, and the ground cable is connected to the position shown in the following figure.

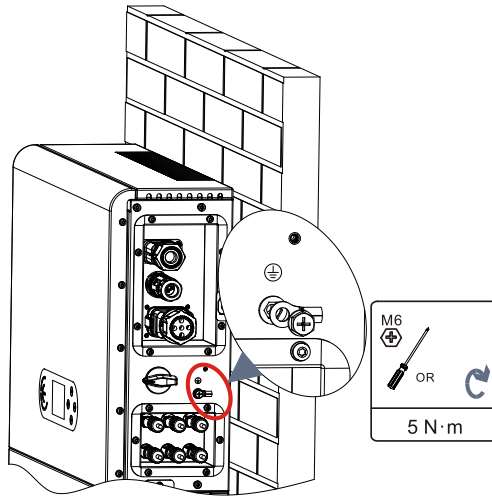

Figure 4.4.4-2 Connect the grounding wire

#### 4.4.2 PV module connection

Recommended DC input cable specifications

CAS (mm <sup>2</sup> )		External cable diameter(mm <sup>2</sup> )
Range	Recommended value	
4.0~6.0	4.0	4.5~7.8

#### Connection Procedure:

**Step 1:** Prepare PV positive and negative power cables;

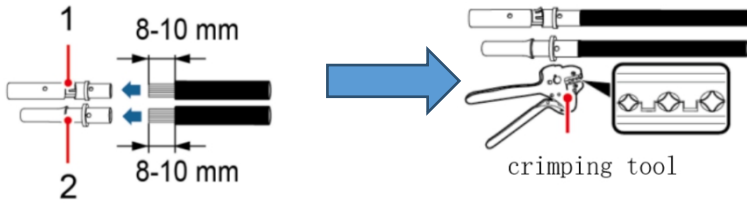

1	Positive connector	2	Negative connector
---	--------------------	---	--------------------

Figure 4.4.2-1 Prepare PV positive and negative power cable

**Step 2:** Insert the crimped photovoltaic positive and negative power cable into the corresponding photovoltaic connector.

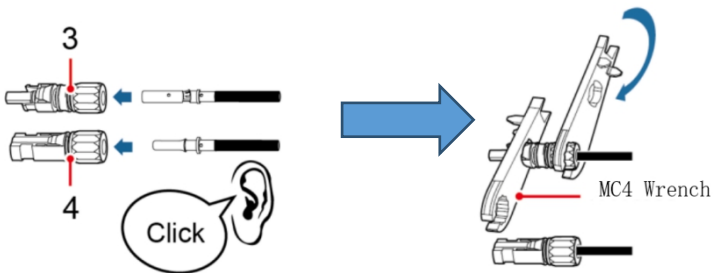

3	Positive connector	4	Negative connector
---	--------------------	---	--------------------

Figure 4.4.2-2 Prepare PV positive and negative connectors

**Step 3:** Ensure that the DC voltage of each PV string is less than 600V and the polarity of PV cables are correct. Insert the positive and negative connectors into the corresponding PV region of the ESI series inverter until a click is heard. As the figure 4.4.2-3 showing.

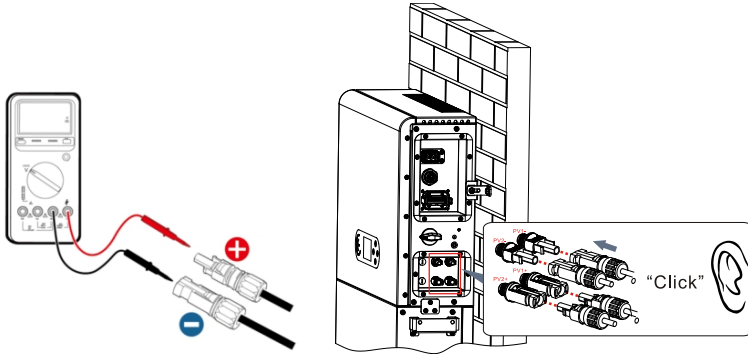



Figure 4.4.2-3 Connect PV connector

 <b>Caution</b>	Ensure that the DC switch is turned off before removing the PV positive and negative connectors.
---	--

**Follow-up Step**

Disconnect the PV connector using an MC4 wrench, as shown in Figure 4-6.

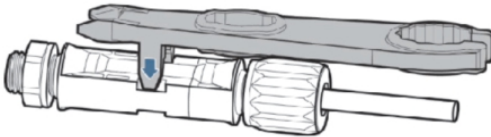

Figure 4.4.2-4 Disconnect PV connectors

**4.4.3 Grid connection**

**Install AC wiring terminals**

Take out AC wiring terminals from the carton of the inverter, strip

and install cables according to the cable specifications listed in Table 4.2-1.

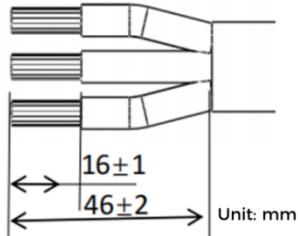
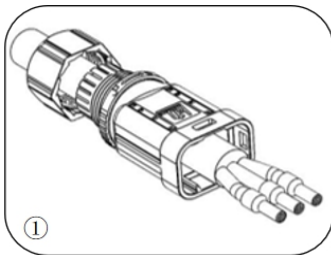
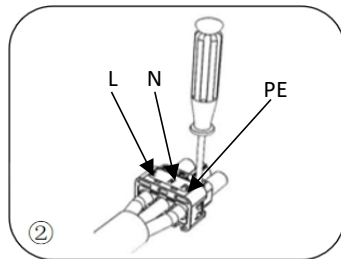

Figure 4.4.3.-1 Wire stripping size

### Installation Step



After riveting the peeling wire to the insulation terminal, thread it into the lock wire nut and the main body.



Insert the cable into the rubber core according to the wire sequence, make the insulation terminal flush with the surface of the rubber core, and press the screw torque  $2.0 \pm 0.1$  n.m

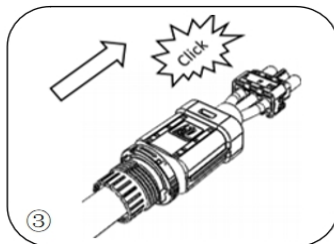

The body is inserted into the core and a click is heard

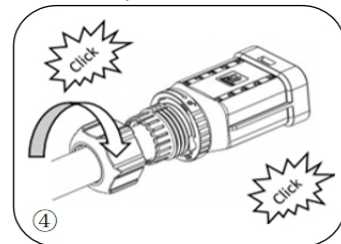

Tighten the nut with an open wrench and make a "click" sound

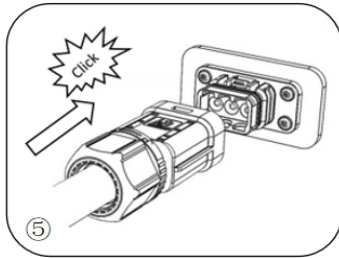

5  
Insert the female end of the wire into the male end and hear a "click" sound

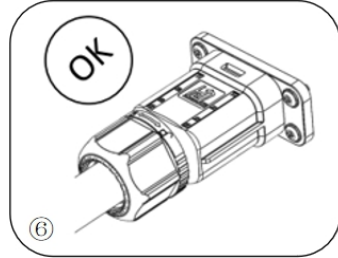

6  
Installation complete

Figure 4.4.3-2 Installation Procedure Diagram

### Removal Step

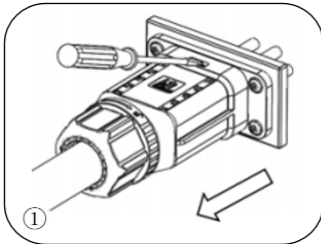

1  
Use a screwdriver to point at the unlocking position, hold the cable driver, and pull it back to separate the male and female

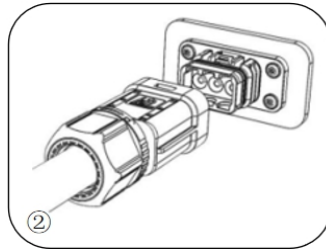

2  
The female connector is separated from the board connector

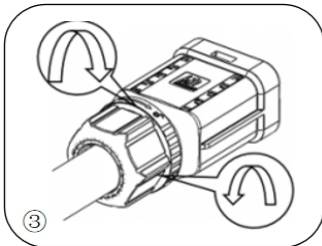

3  
Hold the unlocking buckle with one hand and rotate it in the direction indicated, while rotate the nut in the opposite direction with the other hand

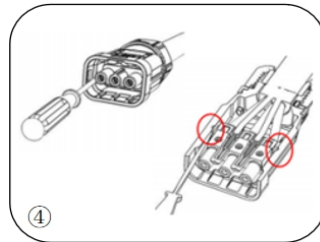

4  
Remove the red circles on both sides using a screwdriver

Figure 4.4.3-3 Removal procedure

Connect the AC wiring terminals to the corresponding AC Grid ports, as shown in the following figure.

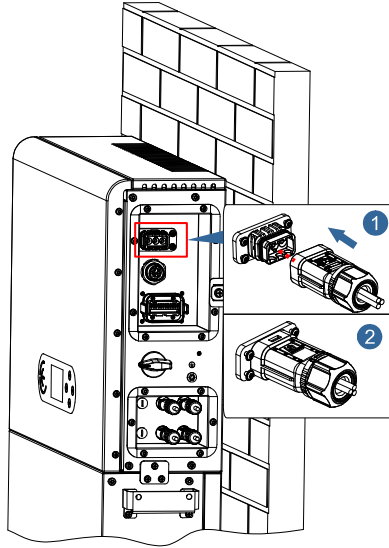

Figure 4.4.3-4 Grid connection

#### 4.4.4 EPS connection

According to the cable specifications given in Table 4.4.1, peel the cable according to the following figure 4.4.4-1. Then install the EPS connector according to 4.4.4-2. Finally, insert the installed EPS connector into the corresponding position of the inverter according to Figure 4.4.4-3.

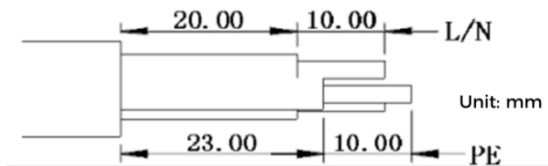
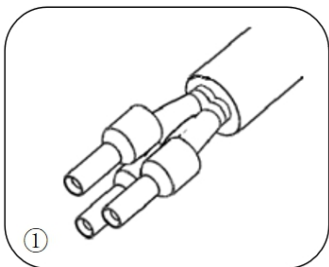
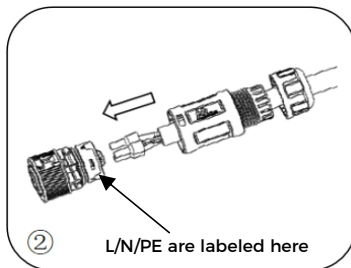

Figure 4.4.4-1 Stripping diagram

### Install procedure



Crimp terminal



Insert the cable into the butt terminal

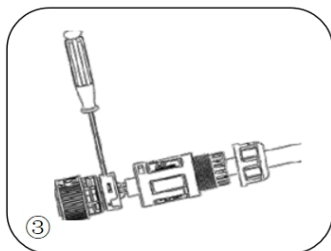

Crimp the wire with an inner hexagon screwdriver with a screw torque of  $1.2 \pm 0.1 \text{ n.m}$

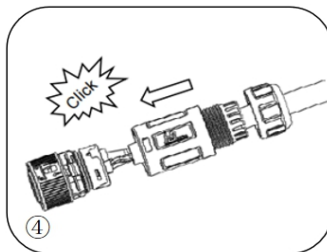

Insert the subject into the corresponding clasp and hear a "click" sound

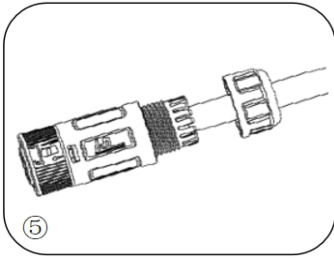

Screw locking nut into main body, torque  $2.5 \pm 0.5 \text{ n.m}$

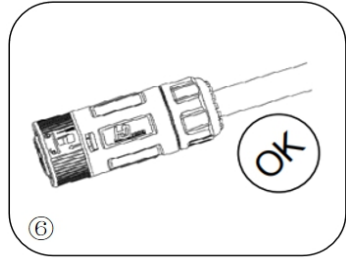

Installation complete

Figure 4.4.4-2 EPS Connector installation

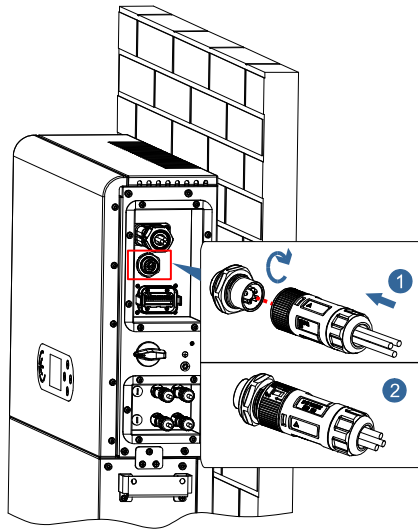

Figure 4.4.4-3 EPS connection

#### 4.4.5 COM-Multi function communication connection

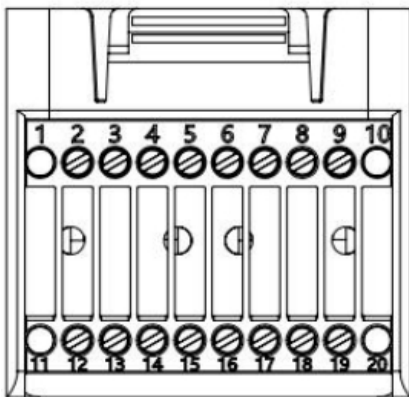

Figure 4.4.5-1 COM port diagram

Table 4.4.5-1 Port description

PIN	Definition	Function	Comment
1	N/A	N/A	
2	UC-A	RS485 differential signal -A	Inverter monitoring 485 signal
3	UC-B	RS485 differential signal -B	
4	EN+	RS485 differential signal +	Battery 485 signal
5	EN-	RS485 differential signal -	
6	MET-A	RS485 differential signal -A	Smart meter 485 signal
7	MET-B	RS485 differential signal -B	
8	CANH	CAN high data	Battery CAN

9	CANL	CAN low data	communication signal
10	N/A	N/A	
11	N/A	N/A	
12	GND	Logic interface signal	(DRMS) Logical interfaces use for below standard Australia (AS4777) , Europe General (50549) , German (4105)
13	D1/5		
14	D4/8		
15	D2/6		
16	D0		
17	D3/7		
18	CT+	Current transformer output positive terminal	Current transformer communication signal
19	CT-	Current transformer output negative pole	
20	N/A	N/A	

Link Port

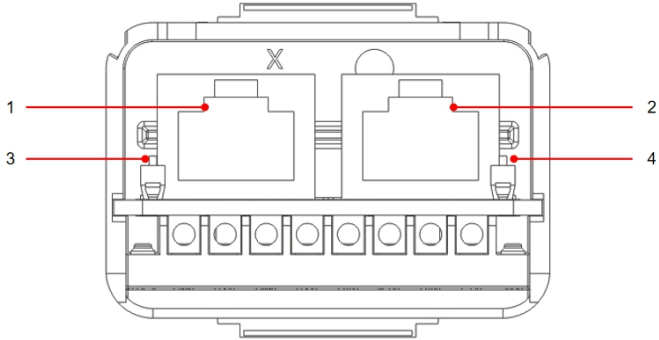

Figure 4.4.5-2 Link Port diagram

Table 4.4.5-2 Link Port description

Icon	Define	Function	Comment
1	Link Port 1	Parallel signal output	Parallel signal port (RJ45)
2	Link Port 0	Parallel signal input	
3	Link Port 1 dip switch	Match resistance on and off	The dial switch has 0 (dial up) and 1 (dial down). 1 means on and 0 means off
4	Link Port 0 dip switch		

The wire stripping is divided into 2 to 9 holes and 12 to 19 holes. The wire stripping size is defined according to the cable connection position

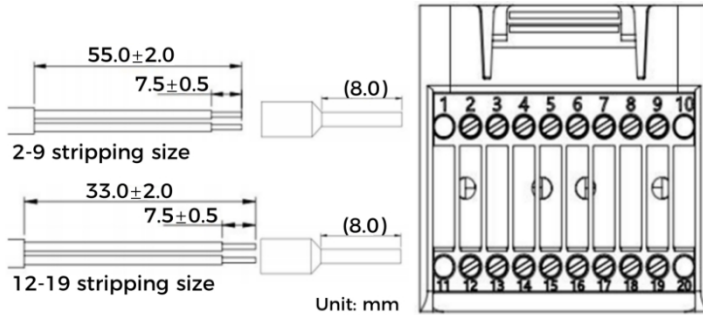

Figure 4.4.5-3 Schematic diagram of wire stripping size

**1. RS485** (Wired monitoring or inverter cascade monitoring)

Refer to the figure shown below, connect the RS485+ and RS485- of the inverter to the TX+ and TX- of the RS485→ USB adapter, and connect the COM port of the adapter to the computer. (NOTE: The length of the RS485 communication cable should be less than 1000 m)

Connect pins as shown(2pin and 3pin)

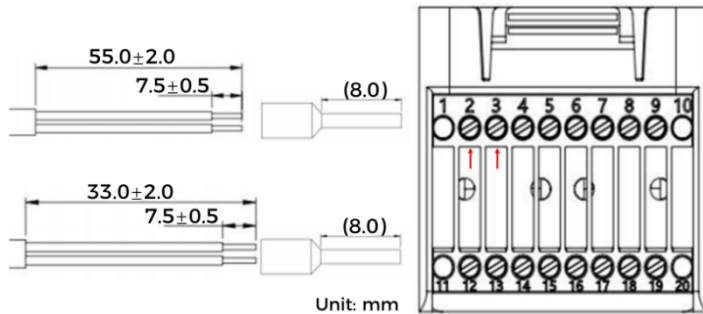



Figure 4.4.5-4 RS485 wiring diagram

RS485 wires are connected in parallel between inverters.

	<p>When multiple inverters are connected via RS485 wires, set communication address to differentiate the inverters, please refer to this manual&lt;6.3.1 System setting→8.Communication Addr&gt;.</p>
<p>Note</p>	

## 2. Logic interface

The logic interface pin definitions and circuit connections are as follows:

Logic interface pin are defined according to different standard requirements

(a) Logic interface for AS/NZS 4777.2:2020, also known as inverter demand response modes (DRMs).

The inverter will detect and initiate a response to all supported demand response commands within 2 s. The inverter will continue to respond while the mode remains asserted.

Table 4.4.5-3 Function description of the DRMs terminal

Pin NO.	Function
12	GND
13	D1/5
14	D4/8
15	D2/6
16	D0
17	D3/7

(b) Logic interface for EN50549-1:2019, is in order to cease active power output within five seconds following an instruction being received at the input interface.

The inverter can be connected to a RRCR (Radio Ripple Control Receiver) in order to dynamically limit the output power of all the inverters in the installation.

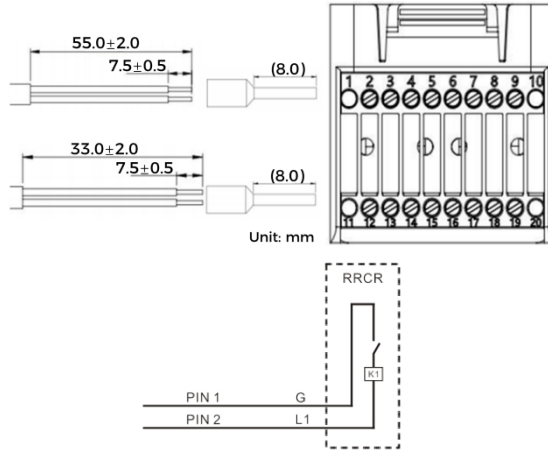

Figure 4.4.5-5 DRMs wiring diagram

Table 4.4.5-4 Function description of the terminal

COM Pin NO.	Pin name	Description	Connected to (RRCR)
PIN 16(PIN2)	L1	Relay contact 1 input	K1 - Relay 1 output
PIN 12(PIN1)	G	GND	K1 - Relay 1 output

Table 4.4.5-5 The inverter is preconfigured to the following RRCR power levels, close is 1, open is 0

L1	Active Power	Power drop rate	Cos(φ)
1	0%	<5 seconds	1
0	100%	/	1

### 3.Meter/CT

PIN6 and PIN7 of COM are used for meter communication, the electricity meter is shown in the Figure 4.4.5-6①, PIN6 and PIN7 correspond to 7, 8 respectively on the electricity meter, as shown

in Figure 4.4.5-6③.

The connection mode is shown in Figure 4.4.5-6②. The 1/2 and 3/4 on the electricity meter are connected to voltage signals L and N respectively. And the current needs to be connected through the current transformer, 6, 7 correspond to the current transformer.

NOTE: The direction of the current transformer is shown in Figure 4.4.5-6④.

Figure 4.4.5-6 Meter

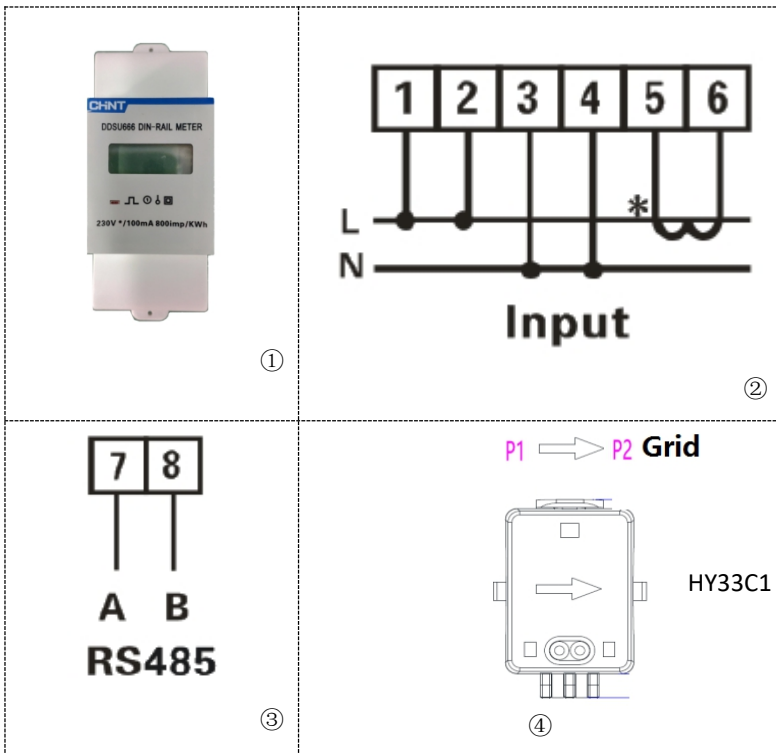

If you need to use the CT alone, attach the CT to PIN18 and PIN19.

There are two ways to get grid current information:

Plan A: CT (default)

Plan B: Meter +CT

If you need to use the meter +CT scheme, please contact SOFAR staff to purchase the appropriate meter and CT.

COM Installation procedure for connecting cables

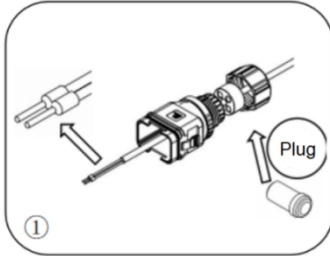

Remove the plug from the plug and thread the terminal in the order shown

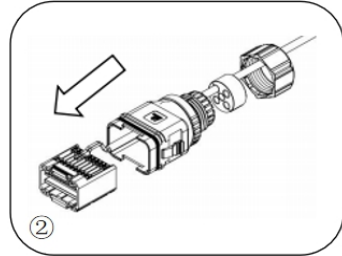

Insert the wire into the corresponding terminal

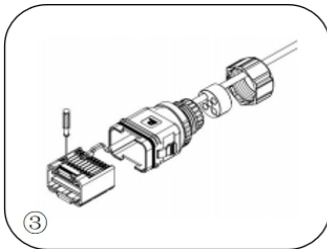

Crimp the wire with a flat-head screwdriver with a torque of  $1.2 \pm 0.1 \text{ n.m}$

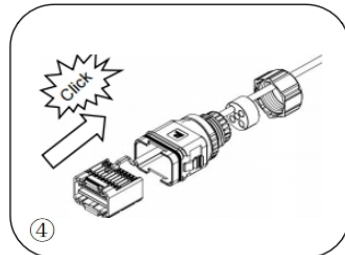

Line core, rubber core area can not appear riding line phenomenon, rubber core into the main body with a "click" sound

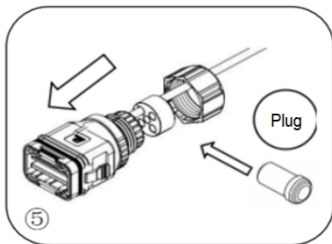

Insert the plug into the body and plug the unwired hole

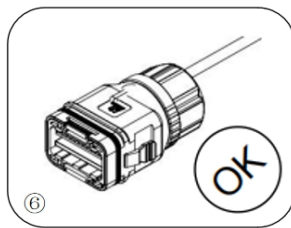

Screw the lock nut into the main body, torque  $2.5 \pm 0.1$  n.m, complete installation

Figure 4.4.5-7 Procedure for connecting COM cables

Insert the stripped COM connector into the corresponding port of the inverter, as shown in the following figure.

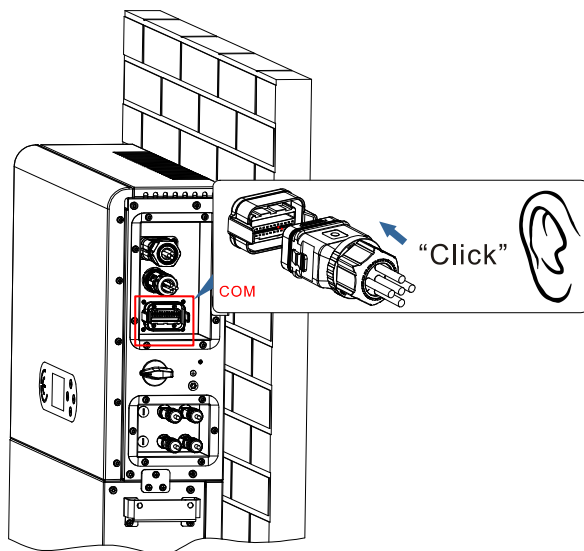

Figure 4.4.5-8 COM connection

#### 4. Feed-in limit function

The feed-in limit function can be used to limit the power fed back into the grid. In order to achieve this function, power measurement devices must be installed according to the system.

**Single-phase limit:** The power output of the inverter to the power grid does not exceed the set power limit value.

**NOTE:**

1) For the Single-phase limit setting, the current sensor must be properly connected to the L line on the meter. The meter wiring is shown in Figure 4.4.5-6. In addition, refer to 5.3.2(3) for feed-in limit settings.

2) If communication with the smart meter is interrupted, the inverter limits its output power to the set power limit value.

##### 4.4.6 Smart Meter /CT

Refer to the COM interface description in Figure 4.4.5-6 Meter, the RS485A and RS485B of the electricity meter should be connected to pin6 and pin7 of the COM port of the inverter.

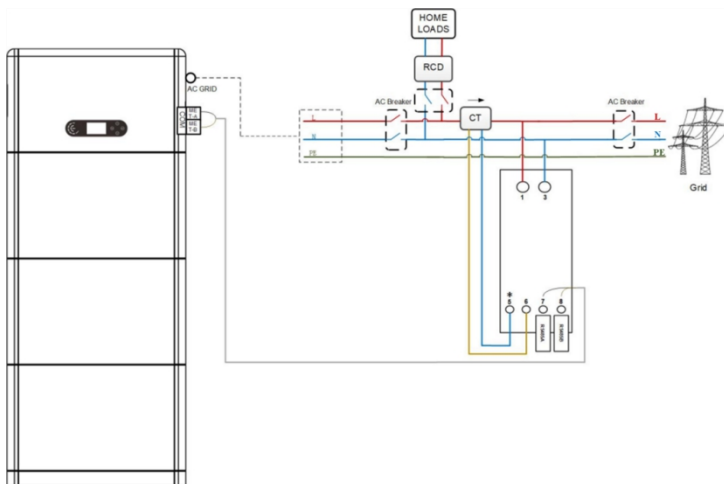

Figure 4.4.6-1 Smart meter/CT connection diagram

#### 4.5 Install the cover

After electrical connections are complete and cable connections are correct and reliable, install the external protective cover and secure it using screws.

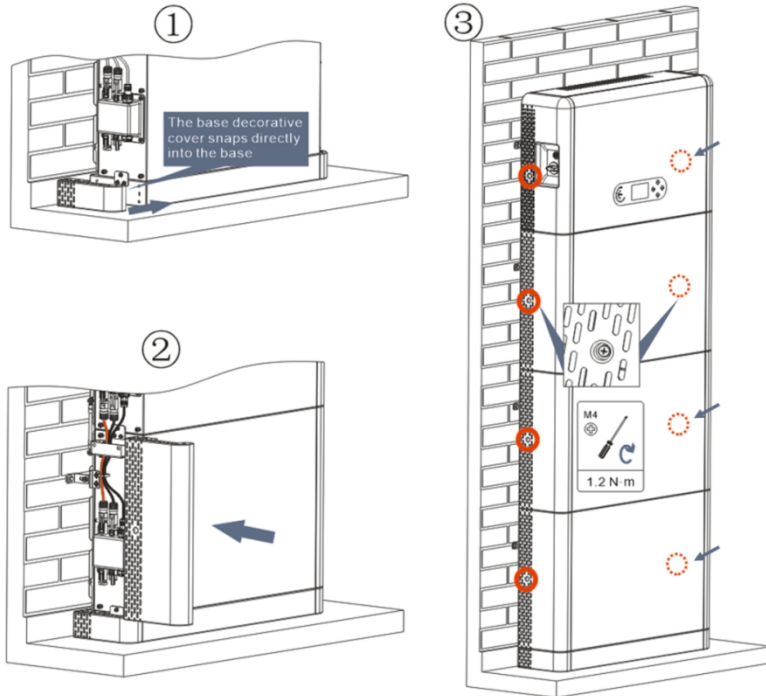

Figure 4.5-1 Install the cover

#### 4.6 Parallel system

Refer to figure 4.6-1 below and connect the system in parallel according to the success of the master and slave (up to 6 units). The dip switch inside the COM 24PIN connector of the last system inverter should be moved to the position of 1.

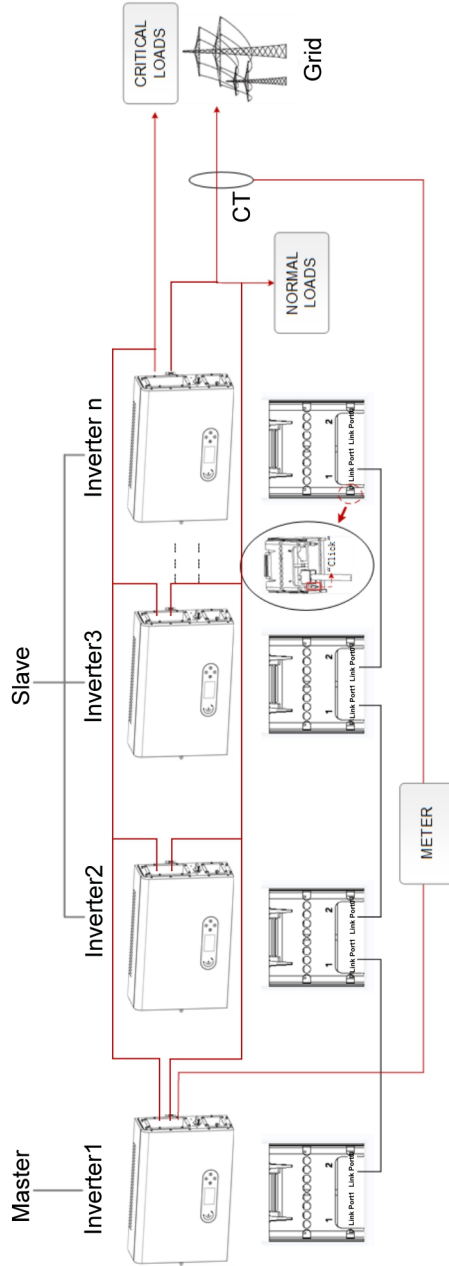

Figure 4.6-1 System parallel diagram

## 4.7 System Electrical Topology

SOFAR has already integrated RCMU (residual current monitoring unit) inside inverter. If an external RCD is required, a type-A RCD with rated residual current of 100mA or higher is suggested.

ESI series household energy storage system is mainly composed of PV modules, BTS 5K battery modules, inverters, AC switches, load and distribution units, smart meters /CT, and power grid.

The inverters AC GRID and AC LOAD are wired with different N and PE wires depending on the regulatory requirements in different regions. For users in Australia, South Africa and New Zealand, please use the System Electrical Topology in Figure 4.7-2.

### **System 1: N and PE lines are wired separately in the distribution box**

The wiring method in Figure 4.7-1 is applicable to areas without special requirements for distribution system wiring.

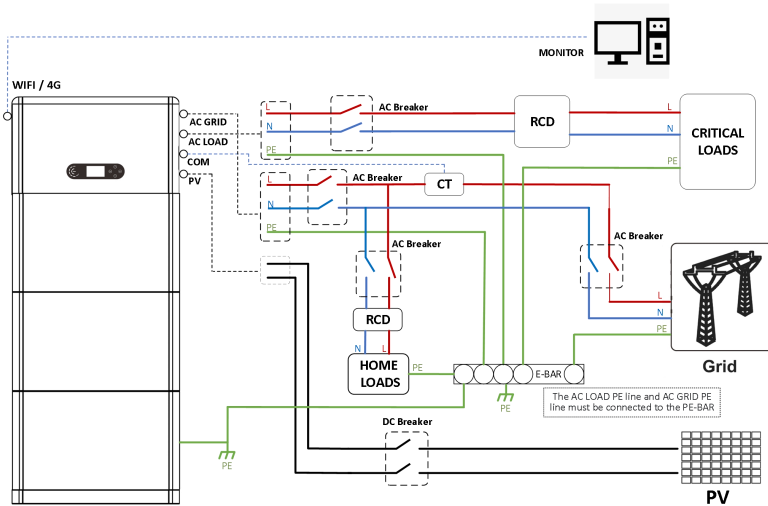



Figure 4.7-1 System Electrical Topology (General)

- a. Ensure that the AC LOAD PE line and AC GRID PE line must be connected to the PE-BAR in the distribution box, as shown in the diagram. Otherwise, the inverter may be abnormal in off-grid mode.
- b. Check whether NeutralPointGrounding is enabled, if not, enable it manually.

2.Advanced setting		Input 0001
11.NeutralPointGrounding		
11. NeutralPointGrounding		Disable
		Enable

## System 2: N and PE lines are connected together in the distribution box

The wiring method in Figure 4.7-2 is applicable to areas where N and PE are connected together in the distribution box, such as Australia, South Africa, New Zealand, etc.

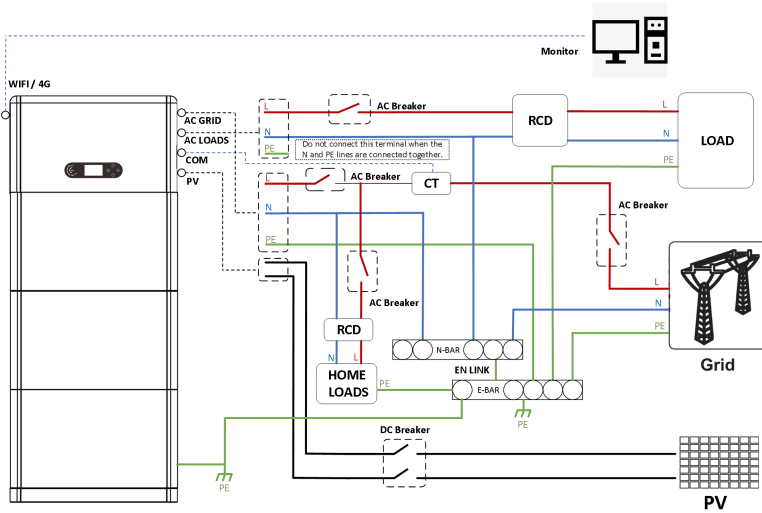





Figure 4.7-2 System Electrical Topology

(For Australia, South Africa and New Zealand)

	<p><b>Install Residual current device (RCD) in front of the load</b></p> <ul style="list-style-type: none"> <li>● <b>RCD is necessary for critical load, but optional for normal load.</b></li> <li>● In off-grid mode, the Entry master switch is unprotected and load leakage could lead to shock danger.</li> <li>● The Entry master switch installed in the house must have earth leakage protection and its rated earth leakage action current &gt; number of inverters * 100mA.</li> </ul>
<p><b>Danger</b></p>	

 <div style="background-color: red; color: white; padding: 5px; text-align: center;"><b>Danger</b></div>	<p><b>Be sure to ensure that the output is grounded</b></p> <ul style="list-style-type: none"> <li>● In system 1, The PE line of the inverter's AC GRID port and AC LOAD port must be grounded through the PE-Bar, otherwise there may be a risk of leakage.</li> </ul>
--	---

 <div style="background-color: #90EE90; padding: 5px; text-align: center;"><b>Note</b></div>	<ul style="list-style-type: none"> <li>● In system 2, NeutralPointGrounding is disabled by default. No manual setup required.</li> </ul>
--	--

## 5 Commissioning

### 5.1 Checking Before System Starting

Please double check the following items before running

1. The product should be completely fixed on the pedestal bracket, and the connection with the wall should be tight and firm.
2. The PV+/PV- line is firmly connected, the polarity is correct, and the voltage is in line with the accessible range.
3. BAT+/BAT- cables are firmly connected, the polarity is correct, and the voltage meets the accessible range.
4. Grid/load cable connections are firm/correct.
5. The inverter power grid port is correctly connected to the power grid and the AC circuit breaker is disconnected.
6. The inverter load port is correctly connected to the emergency load, and the circuit breaker is disconnected.

### 5.2 Electrify for the First Time (Important)

Important: Please follow the steps below to turn on the inverter.

1. Ensure that the phase connected to the inverter of the product does not generate power.
2. Switch the DC switch on the PV side of the product to ON.
3. Switch the DC switch on the battery side of the product to ON, and press the battery black start button to activate the battery.

4. Turn on the AC circuit breaker between the inverter power grid port and the power grid.
5. Turn on the AC circuit breaker between the inverter load port and the emergency load.
6. Press the system power button, and the inverter starts running. The system status indicator is blue.

When the inverter is running, set the following parameters.

Table 6- 1 Setting parameter

Parameter	Comment
1.Menu language selection	Default English
2.Set and confirm system time	If the collector or mobile APP is connected to the monitoring system, the time has been calibrated to the local time
*3.Safety parameter import	Refer to the country code table below and select country and code
4.Setting the input channel	The default order: BAT1, BAT2, PV1, PV2)
5. Setup is complete	

Table 6-2 List of regulated countries

Code		Country	Code		Country
000	000	Germany VDE4105	018	000	EU EN50438
	001	Germany BDEW		001	EU EN50549

	002	Germany VDE0126	019	000	IEC EN61727
001	000	Italia CEI-021 Internal	020	000	Korea
	001	Italia CEI-016 Italia	021	000	Sweden
	002	Italia CEI-021 External	022	000	Europe General
	003	Italia CEI0-21 In Areti	024	000	Cyprus
	000	Australia	025	000	India
002	001	Australia AU-WA	026	000	Philippines
	002	Australia AU-SA	027	000	New Zealand
	003	Australia AU-VIC	028	000	Brazil
	004	Australia AU-QLD		001	Brazil LV
	005	Australia AU-VAR		002	Brazil 230
	006	Australia AUSGRID		003	Brazil 254
	007	Australia Horizon	029	000	Slovakia VSD
	003	000		Spain RD1699	001
004	000	Turkey		002	Slovakia ZSD
005	000	Denmark	033	000	Ukraine
	001	Denmark TR322	035	000	Mexico LV
006	000	Greece Continent	038	000	Wide-Range-60 Hz
	001	Greece island	039	000	Ireland EN50438
007	000	Netherland	040	000	Thailand PEA
008	000	Belgium		001	Thailand MEA
009	000	UK G59/G99	042	000	LV-Range-50Hz
	001	UK G83/G98	044	000	South Africa

010	000	China	046	000	Dubai DEWG
	001	China Taiwan		001	Dubai DEWG MV
011	000	France	107	000	Croatia
	001	France FAR Arrete23	108	000	Lithuania
012	000	Poland			

	<p>It's very important to make sure that you have selected the correct country code according to requirements of local authority.</p>
<b>Caution</b>	<p>Please consult qualified electrical engineer or personnel from electrical safety authorities about this.</p> <p>SHENZHEN SOFARSOLAR Co., Ltd. is not responsible for any consequences arising out of incorrect country code selection.</p>

Table 6-3 Default values for other Settings

Item	Default status
Energy Storage Mode	Self-use Mode
EPS Mode	Disable
Set Feed-in Limit	Disable
IV Curve Scan	Disable
Logic Interface	Disable



### 5.3 Menu

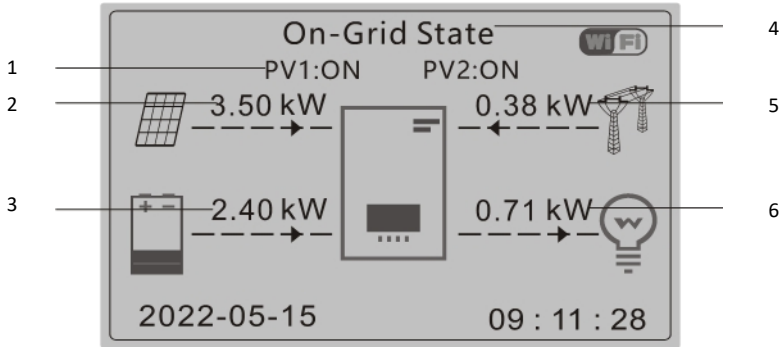

1	Circulates current PV and battery status	4	Display current inverter status
2	PV Power	5	Grid Power
3	Battery Power	6	Loads Power

Figure 6-1 Main interface

In the main interface, press “” button to enter Grid/Battery/PV parameter page.

Main interface		<b>Grid Output Information</b>
		Grid(V).. .....***.V
		AC Power .....**.kW
		Frequency.....**.Hz
		<b>Battery Information</b>
		Batt.....**.V
		Batt Curr.....**.A
		Batt Power.....*.kW
		Batt Temp.....*°C
		Batt SOC.....**%

	Batt Cycles..... *T
	<b>PV Information</b>
	PV1 Voltage ..... ****. *V
	PV1 Current..... **.*A
	PV1 Power..... **.*kW
	PV2 Voltage ..... ****. *V
	PV2 Current..... **.*A
	PV2 Power..... **.*kW
Inverter Temp..... *°C	

In the main interface, press “” button to enter main menu. The main menu has the following six options.

<div style="border: 1px solid black; padding: 5px; width: fit-content; margin: 0 auto;">Main Interface</div> 	1.System Settings
	2.Advanced Settings
	3.Energy Statistic
	4.System Information
	5.Event List
	6.Software Update
	7.Battery Real-time Information

### 5.3.1 System Setting

<div style="border: 1px solid black; padding: 5px; width: fit-content; margin: 0 auto;">1. System Settings</div> 	1.Language Settings
	2.Time
	3.Safety Param.

4.Energy Storage Mode
5.PV Input Mode
6.EPS Mode
7.Communication Addr.

### 1. Language Settings

Used to set the menu display language.

1.Language Settings		1.中文	
		2.English	
		3.Italiano	
		4.Portugues	
		5.日本語	
		6.Deutsch	
		7.Čeština	
		8.Française	
		9.Español	
		10.Polski	
		11.Suomi	

### 2. System Time

Set the system time for the inverter.



2.Time		Time 2022-05-13 17:07:00
--------	---	--------------------------

### 3. Safety Parameter.

3.Safety Param.		1.Select safety regulations
		2.Select USB file

Select the correct safety regulations according to the Table 6-2.

#### 4. Energy Storage Mode

4. Energy Storage Mode		1. Self-use Mode	
		2. Time-of-use Mode	
		3. Timing Mode	
		4. Passive Mode	

##### 4.1 Self-use Mode

In Self-use mode, inverter will automatically charge & discharge the battery.

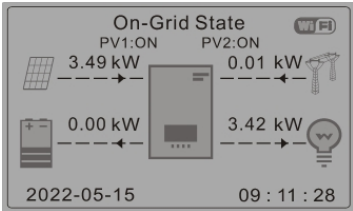
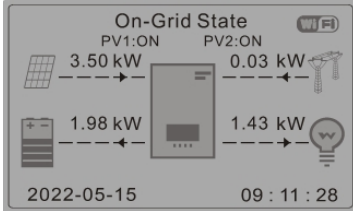
<p>1) If PV power = load power (including emergency load and ordinary load), the inverter will not charge and discharge the battery.</p> 	<p>2) If PV generation &gt; LOAD consumption, the surplus power will be stored in the battery.</p> 
---	---

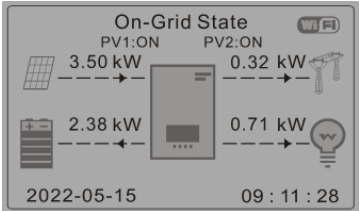
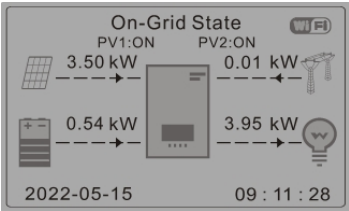
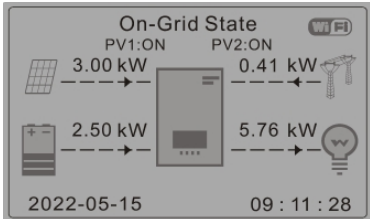
<p>3) If the battery is fully charged or has reached its maximum charging power, the remaining power is sent to the grid (with Anti-countercurrent enabled, the remaining power is not sent to the grid).</p> 	<p>4) If the PV power is less than the load power, the inverter will supply power to the load through battery discharge.</p> 
<p>5) If the PV power plus battery power is still less than the load power, the inverter will purchase power from the grid to supply power to the load.</p> 	

### 5.4 Time-of-use Mode

If electricity is more expensive in high demand time (peak rate) & electricity is much cheaper in low demand time (off-peak rate). You can select an off-peak period to charge your battery. Outside the off-peak charge period, inverter is working in Auto Mode.

If your family normally go to work/school on weekdays & stay at home on weekends, which means the home electricity consumption is much higher on weekends. Thus, you need to store some cheap electricity on weekends only. This is possible using our Time-of-use mode.

In summer, if your PV system can produce more electricity than your home electricity consumption. Then you don't need to set an off-peak charge period to charge your battery in summer at all. You can select an effective date (normally winter) for Time-of-use mode in this case. Outside the effective date, inverter is working in Auto Mode.

You can set multiple Time-of-use rules to meet your more complex requirement. Right now we support 4 rules maximum (rule 0/1/2/3).

2.Time-of-use Mode		Time-of-use Mode			
Rules: 0: Disabled					
From	To	SOC	Charge		
02h00m	- 04h00m	70%	01000 W		
Effective Date					
Dec. 22	-	Mar. 21			
Weekday select					
Mon. Tue. Wed. Thu. Fri. Sat. Sun.					

### 5.5 Timing Mode

Changing the value of a rule can set multiple timing rules.



3. Timing Mode		<p>Timing Mode</p> <p>Rules: 0: Enabled/Disabled</p> <p>Charge Start 22 h 00 m</p> <p>Charge End 05 h 00 m</p> <p>Charge Power 02000 W</p> <p>DisCharge Start 14 h 00m</p> <p>DisCharge End 16 h 00m</p> <p>DisCharge Power 02500 W</p>
----------------	---	---

### 5.6 Passive Mode

4. Passive Mode	
-----------------	---

For more detailed information, please ask representative of SOFAR to get a copy of passive mode communication protocol.

### 5. EPS Mode

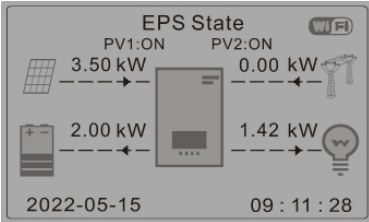
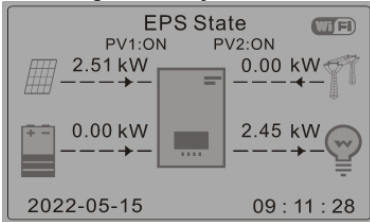
5. EPS Mode		1. EPS Mode Control	
<p>1) If PV generation &gt; LOAD consumption (<math>\Delta P &gt; 100W</math>), inverter will charge battery.</p>		<p>2) If PV generation = LOAD consumption (<math>\Delta P &gt; 100W</math>), inverter won't charge or discharge battery.</p>	
			

3 ) If PV generation < LOAD consumption( $\Delta P > 100W$ ), inverter will discharge battery.

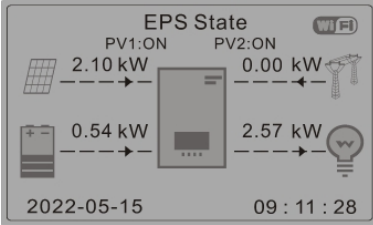



### 6. Communication Addr

6.Communication Addr	↩	1.Communication Addr	↩
		2.Baud Rate	↩

### 5.6.1 Advanced Setting

2.Advanced setting	↩	Input 0001
		1.Battery Parameter
		2.Battery Active
		3.Set Feed-in Limit
		4.IV Curve Scan
		5.Logic Interface
		6.Factory Reset
		7.Parallel Settings
		8. Reset Bluetooth
		9.CT Calibration
		10.Set ElectricityMeter
		11.NeutralPointGrounding

### 1) Battery Parameter

1.Battery Parameter 	1.Battery Number 
	2.Battery1 

### 2) Battery Quantity

Group 1 represents the number of cascading battery modules for the BAT1 port of the inverter.

Group 2 represents the number of battery modules connected to the BAT2 port of the inverter.

### 3) Battery 1

2.Battery 1 	1.Discharge Depth
	2.Set Force Charge Time
	3.Save

### Depth of Discharge

For example: if Discharge Depth = 50% & EPS Discharge Depth = 80%.

While grid is connected: Inverter won't discharge the battery when its SOC is less than 50%.

In case of blackout: Inverter will work in EPS mode (if EPS mode is enabled) & keep discharging the battery till battery SOC is less than 20%.

3.Depth of Discharge 	Discharge Depth 50%
--	------------------------





<p style="text-align: center;"><b>EPS Discharge Depth</b></p> <p style="text-align: center;">80%</p> <p style="text-align: center;"><b>EPS Safety Buffer</b></p> <p style="text-align: center;">20%</p>
---

#### 4) Battery Activation

2.Battery Activation		1.Auto Active Control
		2.Force Active

#### 5) Set Feed-in Limit



Users can limit the maximum power sent from the system to the grid by enabling Feed-in Limit. Counter current power is the maximum power expected to be sent to the grid (e.g., 0KW means no energy is fed into the grid).

3.Set Feed-in Limit		1. Feed-in Limit		Enable
				Disable
		2.Hard Limit Control		Enable
				Disable
		2. Feed-in Power		***kW

#### 6) IV Curve Scan

When a component of PV modules is blocked or abnormal, multiple power peaks occur, the maximum power peaks can be traced by enabling this function.

The user can enter the scan period to make the inverter scan immediately.

3.IV Curve Scan		1.Scan Control		Enable
-----------------	---	----------------	---	--------

		Disable
2.Scan Period		***min
3.Force Scan		

### 7) Logical Interface Control

Enables or disables a logical interface. This feature is only available under certain safety regulations.

4.Logical Interface Control		Enable	
		Disable	

### 8) Factory Reset

5.Factory Reset		1.Clear Energy Data	
		2.Clear Events	

Clear the total energy yield of the inverter.

1.Clear Generated Power		Cancel		Enter <b>0001</b>
-------------------------	--	--------	--	-------------------

Clear the history events of the inverter.

2.Clear List		Cancel	
--------------	--	--------	--

### 9) Parallel Setting

For the parallel system, please refer to <4.6 Parallel System > .

6.Parallel Setting		1.Parallel function control
		2.Parallel Primary-Replica
		3.Set Parallel Address
		4.Save

1. Parallel function control: Enable or disable the parallel



function. This function must be enabled on both the master and slave machines.

2. Set master and slave: Set the master and slave. Select one inverter as the master and the others as slave machines.

3. Set parallel address: Set the parallel address for each inverter. In a parallel system, each inverter should have a parallel address that does not duplicate that of other machines. (Note: Parallel addresses are different from communications addresses used for monitoring.)

4. Save: Be sure to save after the Settings.

### 10) Bluetooth Reset

7. Bluetooth Reset		Please Confirm!		Succeed
--------------------	---	-----------------	---	---------

### 11) CT Calibration

Used to calibrate the orientation and phase of the CT. The battery should be charged or discharged when using this feature.

8. CT Calibration		Start CT Calibration	Succeed/Failed
		Set CT Power Offset	***W



### 12) Set ElectricityMeter

10. Set ElectricityMeter		Disable
		Enable

### 13) NeutralPointGrounding

11. NeutralPointGrounding 	Disable
	Enable

### 5.6.2 Energy Statistic





3. Energy Statistic 	Today
	PV ..... **kWh
	Load ..... **kWh
	Export..... **kWh
	Import..... **kWh
	Charge..... **kWh
	Discharge..... **kWh
	 <span style="background-color: #e1eef6;">Month</span>
	PV ..... **kWh
	Load ..... **kWh
	Export..... **kWh
	Import..... **kWh
	Charge..... **kWh
	Discharge..... **kWh
	 <span style="background-color: #e1eef6;">Year</span>
	PV ..... **kWh
	Load ..... **kWh
	Export..... **kWh
	Import..... **kWh

	Charge..... **kWh
	Discharge..... **kWh
	<b>Lifetime</b>
	PV ..... **kWh
	Load ..... **kWh
	Export..... **kWh
	Import..... **kWh
	Charge..... **kWh
	Discharge..... **kWh

### 5.6.3 System Information

<div style="border: 1px solid black; padding: 5px; background-color: #e1eef6;">4.System Information</div> 	1.Inverter Info
	2.Battery Info
	3.Safety Param.
	4.Debug Info
	5.PCU Info
	6.BMS Info

<div style="border: 1px solid black; padding: 5px; background-color: #e1eef6;">1.Inverter Info</div> 	Inverter Info (1)
	Product SN
	Hardware Version
	Power Level
	Safety Firmware Version

	<b>Inverter Info (2)</b>
	Software Version
	Country
	Safety Lib Version
	<b>Inverter Info (3)</b>
	Input Channel 1
	Input Channel 2
	Input Channel 3
	<b>Inverter Info (4)</b>
	Energy Storage Mode
	RS485 Address
	<b>Inverter Info (5)</b>
	Logic Interface
	Power Factor
	<b>Inverter Info (6)</b>
	Set Feed-in Limit
	Insulation Resistance

**2. Battery Info**

	<b>Battery 1 Info (1)</b>
	Battery Type
	Battery Capacity
	Discharge Depth
	EPS Safety Buffer

▼	Battery 1 Info (2)
	Max Charge (A)
	Max Discharge (A)
	Charge Start
	Charge End

3.Safety parameters.	↩	Safety param(1)
		OVP 1
		OVP 2
		UVP 1
		UVP 2
	▼	Safety param (2)
		OFP 1
		OFP 2
		UFP 1
		UFP 2
	▼	Safety param(3)
		OVP 10mins

### 5.6.4 Event List

Once a fault occurs, the fault information is displayed on the event list page. The event list displays the current event records, including the event ID and occurrence time of each event. You can access the event list screen on the main screen to view

detailed information about real-time events. Events are listed by occurrence time, and the latest events are listed first.

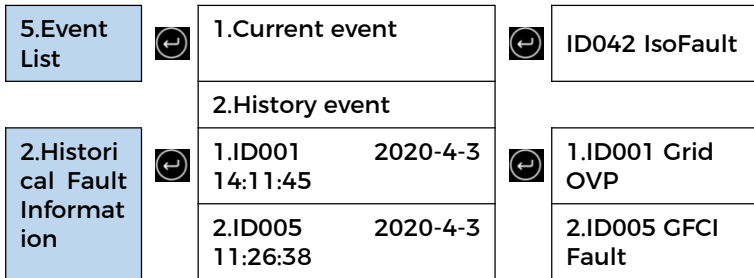

### 5.6.5 Software Update

You can upgrade the software using the USB flash drive to maximize the performance of the product and avoid abnormal operation caused by software bugs.

The upgrade file folder name is firmwareESI. These three upgrade file names are ESI\_ARM.bin, ESI\_DSPM.bin, ESI\_DSPTS.bin.

Step 1 Insert the USB drive into the computer.

Step 2 SOFAR will send the upgraded firmware to the users who need to upgrade. After receiving the file, decompress it and save it in a USB flash drive.

Step 4 Insert the USB disk into the USB/WiFi interface of the machine.

Step 5 Turn on DC switch.

Step 6

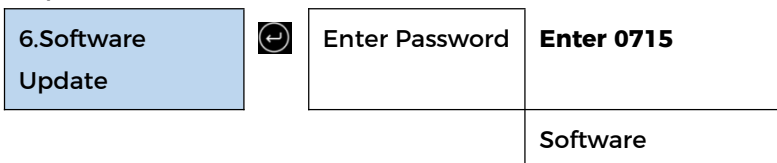

	Update(PCS)
	Software Update(BMS)
	Software Update(PCU)

**Step 7** If the following error occurs, upgrade again. If this situation persists for several times, contact technical support for help.

USB error	DSPM file error	DSPS file error
ARM file error	Upgrading DSPM fail	Upgrading DSPS fail
Upgrading ARM fail		

**Step 8** After the upgrading, turn off the DC switch, wait for the LCD screen to go off, then restore the WiFi connection, and then turn on the DC switch and AC switch again, and the inverter will enter the running state. You can view the current software version in System Info >> Software Version.

## 6 Trouble shooting and maintenance

### 6.1 Troubleshooting

- This section describes the potential errors for this product. Please read carefully for the following tips when doing the troubleshooting:
- View the warning or error information and error codes displayed on the display to record all error information
- If no error message is displayed on the LCD, perform the following steps to check whether the current installation status meets the operating requirements of the inverter:
  - Is inverter be installed in a clean, dry, ventilated environment?
  - Is the DC switch turn off?
  - Are the cable cross section area and length meet the requirement?
  - Are the input and output connection and wiring in good condition?
  - Are the configuration settings correctly for the particular installation?
  - Is the display panel properly connected to the communication cable and intact?
- To view the recorded fault information, perform the following steps: On the home screen, press "XXX" to enter the main menu. Select "Events" and press "XXXX" to enter.

➤ Ground fault alarm

The integrated inverters in this product comply with the ground fault alarm monitoring of IEC 62109-2 clause 13.9. If a grounding fault alarm occurs, the fault will be displayed on the LCD screen with red light on, and the fault can also be found in the fault history. For the machine equipped with WiFi/4G data collector, the alarm information can be seen on the corresponding monitoring website or received through the APP on the mobile phone.

➤ Event list

Table 7-1 Event list

ID No.	Name	Solution
ID001	The grid voltage is too high	If the alarm occurs occasionally, the possible cause is that the electric grid is abnormal occasionally. Inverter will automatically return to normal operating status when the electric grid's back to normal.
ID002	The grid voltage is too low	
ID003	The grid frequency is too high	
ID004	The grid frequency is too low	If the alarm occurs frequently, check whether the grid voltage/frequency is within the acceptable range. If yes, please check the AC circuit breaker and AC wiring of the inverter.

		<p>If the grid voltage/frequency is NOT within the acceptable range and AC wiring is correct, but the alarm occurs repeatedly, contact SOFAR technical support to change the grid over-voltage, under-voltage, over-frequency, under-frequency protection points after obtaining approval from the local electrical grid operator.</p>
ID005	Charge Leakage Fault	<p>Internal faults of inverter, switch OFF inverter, wait for 5 minutes, then switch ON inverter. Check whether the problem is solved.</p> <p>If not, please contact SOFAR technical support.</p>
ID006	OVRT function is faulty	
ID007	LVRT function is faulty	
ID008	Island protection error	
ID009	Transient overvoltage of grid voltage 1	
ID010	Transient overvoltage of grid voltage 2	

ID012	Inverter voltage error	
ID013	Anti-reflux overload	
ID015	Transient overvoltage of inverter voltage	
ID017	Power grid current sampling error	
ID018	Wrong sampling of dc component of grid current	
ID020	Power grid voltage sampling error (AC)	
ID022	Leakage current sampling error (AC)	
ID024	Input current sampling error	
ID029	Leakage current consistency error	
ID030	Grid voltage consistency error	
ID032	Neutral ground fault	

ID034	SPI communication error (AC)	
ID036	Main chip error (AC)	
ID042	Low insulation impedance	Check the insulation resistance between the photovoltaic array and ground (ground), if there is a short circuit, the fault should be repaired in time. If not solved, please contact SOFAR technical support.
ID043	Ground fault	Check ac output PE wire for grounding.
ID044	Error setting input mode	Check the PV input mode (parallel/independent mode) setting of the inverter. If not, change the PV input mode
ID045	CT Fault	Check whether the CT connection is correct
ID046	Input reverse connection error	Check whether the DC input connection is correct
ID047	Parallel Fault	Check whether parallel is enabled Check whether parallel

		addresses overlap Check whether the parallel network is connected properly
ID049	Battery temperature protection	<p>Make sure the inverter is installed in a place free from direct sunlight.</p> <p>Make sure the inverter is installed in a cool/well-ventilated place.</p> <p>Ensure that the inverter is installed vertically and the ambient temperature is lower than the upper limit of the inverter temperature.</p>
ID050	Radiator temperature protection	
ID057	Ambient temperature protection	
ID059	Module temperature protection	
ID065	Unbalanced bus voltage RMS	<p>Internal faults of inverter, switch OFF inverter, wait for 5 minutes, then switch ON inverter. Check whether the problem is solved.</p> <p>If not, please contact SOFAR technical support.</p>
ID066	The transient value of bus voltage is unbalanced	
ID067	Bus undervoltage during grid connection	
ID068	Bus voltage low	

ID069	PV over-voltage	Check whether the PV series voltage (Voc) is higher than the maximum input voltage of the inverter. If yes, adjust the number of PV modules in series and reduce the PV string voltage to fit the input voltage range of the inverter. After correction, the inverter will automatically return to normal state.
ID070	Bat over-voltage	Check whether the battery overvoltage Settings are inconsistent with battery specifications
ID071	LLC BUS overvoltage protection	Internal faults of inverter, switch OFF inverter, wait for 5 minutes, then switch ON inverter. Check whether the problem is solved.  If not, please contact SOFAR technical support.
ID072	Inverter bus voltage RMS software overvoltage	
ID073	Inverter bus voltage instantaneous value software overvoltage	

ID081	Battery overcurrent protection by software	
ID082	Dci overcurrent protection	
ID083	Output instantaneous current protection	
ID084	BuckBoost software overcurrent	
ID085	The output RMS overcurrent	
ID086	PV overcurrent software protection	
ID087	PV flows in uneven parallel	
ID088	Unbalanced output current	
ID097	LLC bus hardware overvoltage	
ID098	Inverter bus hardware overvoltage	
ID099	BuckBoost	

	hardware overcurrent	
ID100	Battery hardware overcurrent	
ID102	PV hardware overcurrent	
ID103	Ac output hardware overcurrent	
ID105	Meters communication fault	<p>Check whether the meter is enabled</p> <p>Check whether the meter wiring is correct</p>
ID107	Hardware version error	<p>Internal faults of inverter, switch OFF inverter, wait for 5 minutes, then switch ON inverter. Check whether the problem is solved.</p> <p>If not, please contact SOFAR technical support</p>
ID110	Overload Protection	Check whether the inverter works in overload state.
ID113	Overtemperature derating	<p>Make sure the inverter is installed in a place free from direct sunlight.</p> <p>Make sure the inverter is</p>

		<p>installed in a cool/well-ventilated place.</p> <p>Ensure that the inverter is installed vertically and the ambient temperature is lower than the upper limit of the inverter temperature.</p>
ID114	Frequency derating	<p>Make sure the grid frequency and voltage are within acceptable range.</p>
ID115	Frequency loading	
ID116	Voltage derating	
ID117	Volatge loading	
ID124	Battery low voltage protection	<p>Check whether the battery voltage is too low or the battery discharge depth is too low.</p>
ID125	Battery low voltage shutdown	
ID129	Output hardware overcurrent permanent fault	<p>Internal faults of inverter, switch OFF inverter, wait for 5 minutes, then switch ON inverter. Check whether the problem is solved.</p> <p>If not, please contact SOFAR technical support.</p>
ID130	Bus overvoltage permanent fault	
ID131	Bus hardware overvoltage permanent fault	
ID132	PV unbalance current permanent	

	fault	
ID133	EPS mode battery overcurrent	
ID134	Output transient overcurrent permanent fault	
ID135	Output current imbalance permanent fault	
ID137	Input mode setting error	Check the PV input mode (parallel/independent mode) Settings of the inverter.
ID138	Input overcurrent permanent fault	If not, change the PV input mode.
ID139	Input hardware overcurrent permanent fault	Internal faults of inverter, switch OFF inverter, wait for 5 minutes, then switch ON inverter. Check whether the problem is solved. If not, please contact SOFAR technical support.
ID140	Relay permanent fault	
ID141	Bus unbalance permanent fault	
ID142	DC SPD fault	
ID144	Grid relay permanent fault	

ID145	USB fault	Check the USB port of the inverter.
ID146	Wifi fault	Check the WIFI connection of the inverter.
ID147	Bluetooth fault	Check the bluetooth connection of the inverter.
ID148	RTC clock fault	<p>Internal faults of inverter, switch OFF inverter, wait for 5 minutes, then switch ON inverter. Check whether the problem is solved.</p> <p>If not, please contact SOFAR technical support.</p>
ID149	Communication board EEPROM error	
ID150	Communication board FLASH error	
ID152	Safety parameter version error	
ID153	SCI communication error (DC)	
ID154	SCI communication	

	error (AC)	
ID155	SCI communication error (FU)	
ID156	Inconsistent software versions	Contact technical support to obtain the upgrade software.
ID157	Lithium battery communication error	<p>Make sure the battery you use is compatible with the inverter.</p> <p>CAN communication is recommended. Check whether the communication cable or port between the battery and the inverter is faulty.</p>
ID161	Force shutdown	The inverter is forced to shut down.
ID162	Remote shutdown	The inverter is shut down remotely.
ID163	Drms0 shutdown	The inverter is Drms0 shut down.
ID165	Remote derating	The inverter is derating remotely
ID166	Logic interface derating	The inverter is Logic interface. Derating.

ID167	Anti reflux derating	The inverter is Anti reflux derating.
ID169	Fan fault	Check whether fan of the inverter works properly.
ID177	BMS over-voltage alarm	The lithium battery is faulty. Shut down the inverter and lithium battery. Wait for 5 minutes and start the inverter and lithium battery. Check whether the problem is rectified. If not, contact technical support.
ID178	BMS under-voltage alarm	
ID179	BMS high temperature alarm	
ID180	BMS low temperature alarm	
ID181	BMS charge and discharge overcurrent	
ID182	BMS Short circuit alarm	
ID183	BMS Version inconsistency	
ID184	BMSCAN Version inconsistency	
ID185	BMS CAN Version is too low	
ID801	The charging soft	

	start failed	problem is not resolved, please contact technical support.
ID802	The discharging soft start failed	
ID807	PCU version inconsistency	Check whether the number of batteries is set correctly. If the setting is correct, please contact technical support to upgrade software.
ID808	Radiator 1 high temperature alarm	Please make sure the battery is installed in a cool well-ventilated place. If The battery is installed correctly, please contact technical support.
ID809	Ambient high temperature alarm	
ID813	Charging prohibition alarm	If the battery is almost fully, no action is required. Otherwise, please contact technical support.
ID814	Discharging prohibition alarm	If the battery is almost empty, no action is required. Otherwise, please contact technical support.
ID864	Over temperature protection of radiator 1	Power off and wait for 2 hours. If the problem is not solved, please contact technical support.
ID865	Over temperature	

	protection of ambient temperature	
ID867	Can1 communication failure	If this fault occurs occasionally, wait a few minutes to see whether the problem is solved. If this fault occurs frequently, please contact technical support.
ID872	Bus software overvoltage	
ID873	Bus software undervoltage	
ID874	Battery software overvoltage	
ID875	Battery software undervoltage	
ID876	Battery software overcurrent	
ID879	Hardware overcurrent	
ID880	Permanent bus overvoltage	Restart the battery and wait for minutes. If the problem is not resolved, please contact technical support.
ID881	Permanent battery undervoltage	
ID882	Permanent Instant overcurrent	
ID883	Permanent	

	hardware overcurrent	
ID894	Permanent battery activation failed	
ID895	Permanent bus reverse connection	Check whether the wiring is correct and restart the battery. If the problem is not resolved, please contact technical support.
ID896	Battery status error	Restart the battery. If the problem is not resolved, please contact technical support.
ID897	PWM mode error	
ID898	BMS version error	
ID899	BMS overvoltage and overcurrent fault	If this fault occurs occasionally, wait a few minutes to see whether the problem is solved. If this fault occurs frequently, please contact technical support.
ID900	Battery average overcurrent protection	
ID901	Average overload protection	
ID903	Software CBC overcurrent protection	
ID904	Pack ID error	

		not resolved, please contact technical support.
ID928	Battery reversal	Check whether the wiring is correct and restart the battery. If the problem is not resolved, please contact technical support.
ID929	Fusing fault	Restart the battery. If the problem is not resolved or occurs frequently, please contact technical support.

## 6.2 Daily Maintenance

This product usually does not require maintenance or calibration, but ensure that the inverter and the heat sink of the battery module are not covered by dust or dirt.

- Clean the inverter and battery modules:

Please clean the inverter with an air blower, a dry & soft cloth or a soft bristle brush. Do NOT clean the inverter with water, corrosive chemicals, detergent, etc.

- Clean radiator:

In order to ensure the normal function and long service life of the product, it is necessary to ensure that there is enough air flow space around the radiator at the rear of the product, and there is no material around the radiator that obstructs the air flow, such as dust or snow, must be removed. Clean the radiator with compressed air, a soft cloth, or a soft brush. Do not use water, corrosive chemicals, cleaning agents, or strong detergents to clean the heat sink.

## 6.3 Store and charge the battery module

Battery module storage requirements:

- Environment temperature:  $-10^{\circ}\text{C}\sim 50^{\circ}\text{C}$ , Recommended storage temperature:  $25^{\circ}\text{C}\sim 35^{\circ}\text{C}$ .
- Storage relative humidity range: 5%~70%.
- Store in a dry, clean, and ventilated environment, away from direct sunlight.
- If the battery module is stored for a long time, replenish

the power supply periodically. Battery module power supply requirements: the charging current is less than or equal to 7A, and the battery module needs to be charged to 50%SOC.

➤ **Recharge Requirements During Normal Storage**

When the battery is stored for a long time, you need to perform regular maintenance. If the storage time is close to that shown in the following table, arrange supplementary power supply in time.

Recharge conditions when in storage

Storage Environment Temperature	Relative Humidity of Storage Environment	Storage Time	SOC
< -10℃	/	Prohibit	/
-10℃~25℃	5%~70%	≤12 months	30%≤SOC≤60%
25℃~35℃	5%~70%	≤6 months	30%≤SOC≤60%
35℃~45℃	5%~70%	≤3 months	30%≤SOC≤60%
> 45℃	/	Prohibit	/



➤ **Recharge Requirements When Over Discharged**

Recharge the battery within the time range specified in the following table (90%DOD). Otherwise, the overdischarged battery module will be damaged.

Recharge conditions when battery is over discharged

Storage Environment Temperature	Storage Time	Note
-10℃~25℃	≤15 days	/
25℃~45℃	≤7 days	30%≤SOC≤60%
-10℃~45℃	≤12 hours	/

## 7 Datasheet

	<ul style="list-style-type: none"> <li>The following parameters may change without notice , please refer to the user manual and <a href="#">DataSheet</a> on our website.</li> </ul>					
Note						
Model	ESI 3/3.68/ 4/4.6/5/ 6K-S1- HA1	ESI 3/3.68/4 /4.6/5/6 K-S1-H A2	ESI 3/3.68/ 4/4.6/5/ 6K-S1- HA3	ESI 3/3.68/4 /4.6/5/6 K-S1-HA 4	ESI 3/3.68/4/ 4.6/5/6K- S1-HA5	ESI 3/3.68/4/ 4.6/5/6K- S1-HA6
System Schematic						
Inverter Module	ESI 3/3.68/4/4.6/5/6K-S1					
Number of Inverter Modules	1					
Battery Module	BTS 5K					
Number of Battery Modules	1	2	3	4	5	6
Battery Total Energy[1]	5.12 kWh	10.24 kWh	15.36 kWh	20.48 kWh	25.6 kWh	30.72 kWh
IP Rating	IP65					
Operating	Charge: 0°C to +50°C/ Discharge: -10°C to +50°C					

Temperature[2]							
Allowable Relative Humidity Range	5%-95%						
Max. Operating Altitude[3]	4000 m						
Weight	74.5 kg	125.5 kg	176.5 kg	228.5 kg	279.5 kg	330.5 kg	
Dimensions(W*H*D)[4]	708*830*170 mm	708*1250*170 mm	708*1670*170 mm	708*1250*170 mm	708*1250*170 mm	708*1250*170 mm	708*1670*170 mm
Base Dimensions(W*H*D)	620*60*170 mm (floor installation) 620*310*170 mm (wall-mounted installation)						
Display	LCD & APP						
Communication	CAN/RS485/WiFi, Optional: 4G/LAN						
Product Ordering Model	[ESI 3/3.68/4/4.6/5/6K-S1 Inverter Module] + N * [BTS 5K Battery Module]						
Inverter Module	ESI 3K-S1	ESI 3.68K-S1	ESI 4K-S1	ESI 4.6K-S1	ESI 5K-S1	ESI 5K-S1-A	ESI 6K-S1

PV Input							
Recommended Max. PV Power	4500 Wp	5400W p	6000W p	6900W p	7500W p	7500W p	9000 Wp
Max. input voltage	550 Vd.c.						
Start-up Voltage	100 Vd.c.						
Rated Input Voltage	360 Vd.c.						
MPPT Voltage Range	85-520 Vd.c.						
Number of MPP Trackers	1/1						
Max. Input Current	16/16 A						
Max. Isc	22.5/22.5 A						
Battery							
Rated Voltage Range	400 Vd.c.						
Max. Charging/Discharging Current	20 A						

AC Input(Grid)							
Rated Input Voltage	L+N+PE,220/230/240 Va.c.						
Rated Input Frequency	50/60 Hz						
Max. Input Current	27.3/	33.5/	36.4/	41.8/	45.5/	45.5/	54.5
	26.1/	32.0/	34.8/	40.0/	43.5/	43.5/	/52.
	25.0	30.7	33.3	38.3	41.7	41.7	2/50
	A	A	A	A	A	A	.0 A
AC Output(Backup)							
Rated Output Voltage	L+N+PE,220/230/240 Va.c.						
Rated Output Frequency	50/60 Hz						
Rated Output Power	3 kW	3.68 kW	4 kW	4.6 kW	5 kW	5 kW	6 kW
Max. Apparent Power	3 kVA	3.68 kVA	4 kVA	4.6 kVA	5 kVA	5 kVA	6 kVA
Peak Output Apparent Power	450 0VA, 60s	5520 VA, 60s	6000 VA, 60s	6900 VA, 60s	7500 VA, 60s	7500 VA, 60s	900 0V A, 60s
Switching Time	10 ms default						

General Parameter	
Dimensions(W*H*D)	708*410*170 mm
Weight	22.5 kg
Battery Module	BTS 5K
Battery Type	LFP
Battery Module Energy	5.12 kWh
Rated Power	2.5 kW
Topology	Isolation
Dimensions(W*H*D)	708*420*170 mm
Weight	50 kg

[1] Test conditions: 0.2C charging/discharging at 25°C,100%DOD.

[2] Please refer to the temperature derating curve.

[3] If the altitude is >2000 m, derating is required. Please refer to the derating curve.

[4] Dimensions of the inverter and batteries.

## 8 Manufacturer's Warranty and Liability Terms

### **SOFAR standard warranty document**

Warranty period and calculation method of SOFAR battery products refer to the Quality Assurance Agreement of SOFAR ESI Series Household Energy Storage System.

### **Extended warranty period**

If the purchased battery exceeds the warranty period stipulated in the Warranty Agreement of SOFAR ESI Series Household Energy Storage System, the customer can apply for the extended warranty period by providing the serial number of the product to the sales team of the company, and the Company has the right to reject the purchase application for the extended warranty period that does not meet the requirements.

If the original buyer wants to apply for the extended warranty service, please contact the sales team of SHENZHEN SOFARSOLAR Co., LTD to purchase the products that exceed the extended warranty period but have not passed the warranty period stipulated in the Warranty Agreement of SOFAR ESI Series Household Energy Storage System, the original buyer shall bear different extended premiums.

Upon purchase of the extended warranty service, our company will issue an extended warranty card to the customer to confirm

the extended warranty period.

### **Invalid warranty clause**

Equipment failure caused by the following reasons is not covered by the warranty:

- 1) The "warranty card" has not been sent to the distributor or Shenzhen SOFARSOLAR Co., LTD;
- 2) Without the consent of SHENZHEN SOFARSOLAR Co., LTD to change equipment or replace parts;
- 3) Use unqualified materials to support SHENZHEN SOFARSOLAR Co., LTD 's products, resulting in product failure;
- 4) Technicians who don't belong to SOFARSOLAR Co., LTD modify or attempt to repair and erase the product serial number or silk screen;
- 5) Incorrect installation, debugging and use methods;
- 6) Failure to comply with safety regulations (certification standards, etc.);
- 7) Damage caused by improper storage by dealers or end users;
- 8) Transportation damage (including scratches caused by internal packaging during transportation). Please claim directly from the transportation company or insurance company as soon as possible and obtain damage identification such as container/package unloading;
- 9) Failure to follow the product user manual, installation manual and maintenance guidelines;

- 10) Improper use or misuse of the device;
- 11) Poor ventilation of the device;
- 12) The product maintenance process does not follow relevant standards;
- 13) Failure or damage caused by natural disasters or other force (such as earthquake, lightning strike, fire, etc.

Version 4.0



ENERGY TO POWER YOUR LIFE

**ADDRESS**

11/F., Gaoxinqi Technology Building,  
Xingdong Community, Xin'an Sub-district,  
Bao'an District, Shenzhen City, China

**EMAIL**

[info@sofarsolar.com](mailto:info@sofarsolar.com)

**WEBSITE**

[www.sofarsolar.com](http://www.sofarsolar.com)

